

T-8452A

パーツブック
PARTS BOOK

2本針本縫ダイレクトドライブ角縫自動糸切りミシン
TWIN NEEDLE DIRECT DRIVE SPLIT NEEDLE BAR LOCK STITCHER
WITH THREAD TRIMMER

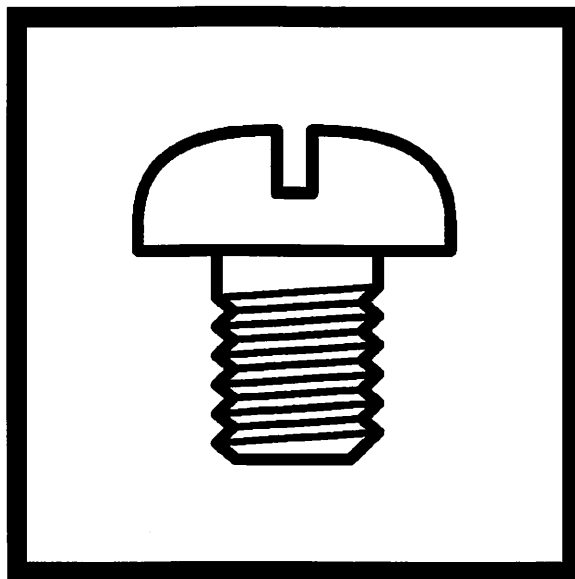

brother[®]

最新の部品情報は Parts Navigation でご覧いただけます。 <http://partsbook.brother.co.jp/partsnavi/jpn/index.html>
The latest parts information, refer to the Parts Navigation. <http://partsbook.brother.co.jp/partsnavi/eng/index.html>

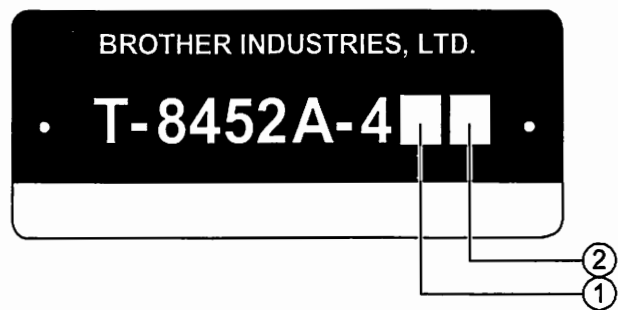

① — 0: 微量給油仕様 / Minimum lubrication type

② — 3: 中厚物 / Medium-weight materials
5: 厚物 / Heavy-weight materials

パーツブックご利用に際して

1. この本は、2005年01月のデータに基づいて作成されたものです。
2. 部品は予告なしに設計変更される場合があります。
3. 組単位で補給する部品は、破線で示してあります。
4. 部品コード欄が * となっている場合は、仕様別部品一覧表及びゲージ部品一覧表でお調べ下さい。
(52から56ページ)

目 次

A. 主体関係	1
B. 上軸関係	3
C. 針棒揺動関係	5
D. 針棒切替操作関係	9
E. 押え関係	11
F. 送り関係	13
G. 逆転関係	15
H. 逆転スイッチ関係	15
J. 送り軸関係	17
K1. かま関係	19
K2. かま関係	23
L. ゲージ関係	23
M. 下軸関係	25
N. 糸締め関係	25
P. 給油潤滑関係	27
Q. 糸通し関係	31
R. 糸巻関係	33
S. 糸切り関係	35
T. 糸払い関係	37
U1. コントロールボックス、モータ関係	39
U2. コントロールボックス関係	41
V. 電装品関係	44
W. 電磁押え上げセット関係(オプション部品)	45
Z1. 付属品関係	47
Z2. 付属品関係	49
Wa. 警告ラベル	51
Sp. 仕様別部品一覧表	52
Ga1. ゲージ一覧表	53
索引	57

Notes for using this parts book

1. This book was prepared based on information available in January 2005.
2. Parts are subject to changes in design without prior notice.
3. Parts supplied as complete assemblies are circled by a dotted line .
4. If the symbol * is found in the " Parts No." column, refer to the different parts lists, gauge parts list on page 52 -56.

CONTENTS

A. Machine body	1
B. Upper shaft mechanism	3
C. Needle bar rocking mechanism	5
D. Needle bar flip-up mechanism	9
E. Presser foot mechanism	11
F. Feed mechanism	13
G. Quick reverse mechanism	15
H. Quick reverse switch mechanism	15
J. Feed shaft mechanism	17
K1. Rotary hook mechanism	19
K2. Rotary hook mechanism	23
L. Gauge parts	23
M. Lower shaft mechanism	25
N. Tension release mechanism	25
P. Lubrication	27
Q. Threading mechanism	31
R. Bobbin winder mechanism	33
S. Thread trimmer mechanism	35
T. Thread wiper mechanism	37
U1. Control box and motor mechanism	39
U2. Control box mechanism	41
V. Power supply equipment mechanism	44
W. Presser foot lifting solenoid set (Option parts)	45
Z1. Accessories	47
Z2. Accessories	49
Wa. Warning labels	51
Sp. Different parts list	52
Ga1. Gauge parts list	53
Index	57

A. 主体関係 / Machine body

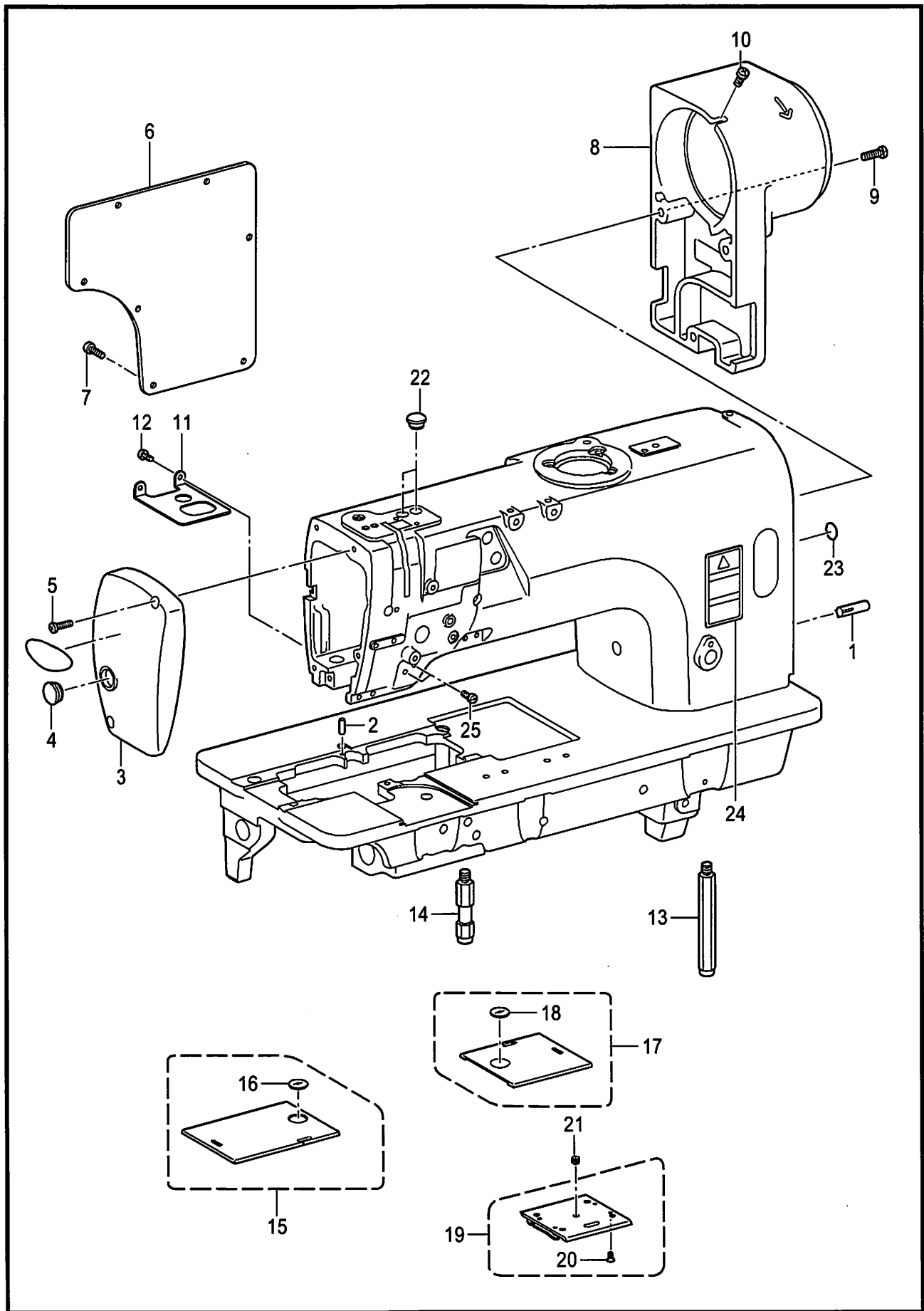

from the library of Diamond Needle Corp

A. 主体関係 / Machine body

REF.NO	CODE	QTY	品名	NAME OF PARTS	RM
1	140063001	2	ミゾツキピン	DOWEL PIN	
2	SA3924001	1	ハリイタイチキメピン	POSITIONING PIN	
3	SA4364001	1	メンイタ	FACE PLATE	
4	104449001	1	ゴムセン15.5	RUBBER CAP, 15.5	
5	062501416	2	ナベコ5X14	SCREW PAN M5X14	
6	SA2441001	1	ガワイタ	REAR COVER	
7	062501216	7	ナベコ5X12	SCREW, PAN M5X12	
8	SA2442101	1	モータカバー	MOTOR COVER	
9	062501416	3	ナベコ5X14	SCREW, PAN M5X14	
10	062501016	1	ナベコ5X10	SCREW, PAN M5X10	
11	SA4370101	1	ダストプレート	DUST PROTECTOR	
12	062500616	2	ナベコ5X6	SCREW, PAN M5X6	
13	SA2444101	1	キヤクチュウL	BED LEG,L	
14	SA2445101	1	キヤクチュウS	BED LEG,S	
15	SA2447001	1	スベリイタLAクミ	SLIDE PLATE, LA ASSY	
16	SA2479001	1	スベリイタマド	BOBBIN WINDOW	
17	SA2449001	1	スベリイタRクミ	SLIDE PLATE ASSY, R	
18	SA2479001	1	スベリイタマド	BOBBIN WINDOW	
19	S36663051	1	スベリイタFクミ	SLIDE PLATE F ASSY	
20	S34438051	4	サラネジ3.18X4	SCREW, FLAT SM3.18-40X4	
21	116010001	1	トメネジ5.16	SET SCREW, SM5.16-40X4	
22	SA2929001	2	ゴムセン12.5	RUBBER CAP, 12.5	
23	S37060001	1	ア-スマーク	LABEL, GROUNDING	
			< 日本向用 >	< For Japan only >	
24	SA2040001	1	ラベルチュウイ.ワイ	LABEL, CAUTION JPN/ENG	
			< 日本向以外用 >	< Except for Japan >	
24	SA2041001	1	ラベルチュウイ.チュウエイ	LABEL, CAUTION CHN/ENG	
25	062500816	2	ナベコ5X8	SCREW PAN M5X8	

from the library of Diamond Needle Corp

B . 上軸関係 / Upper shaft mechanism

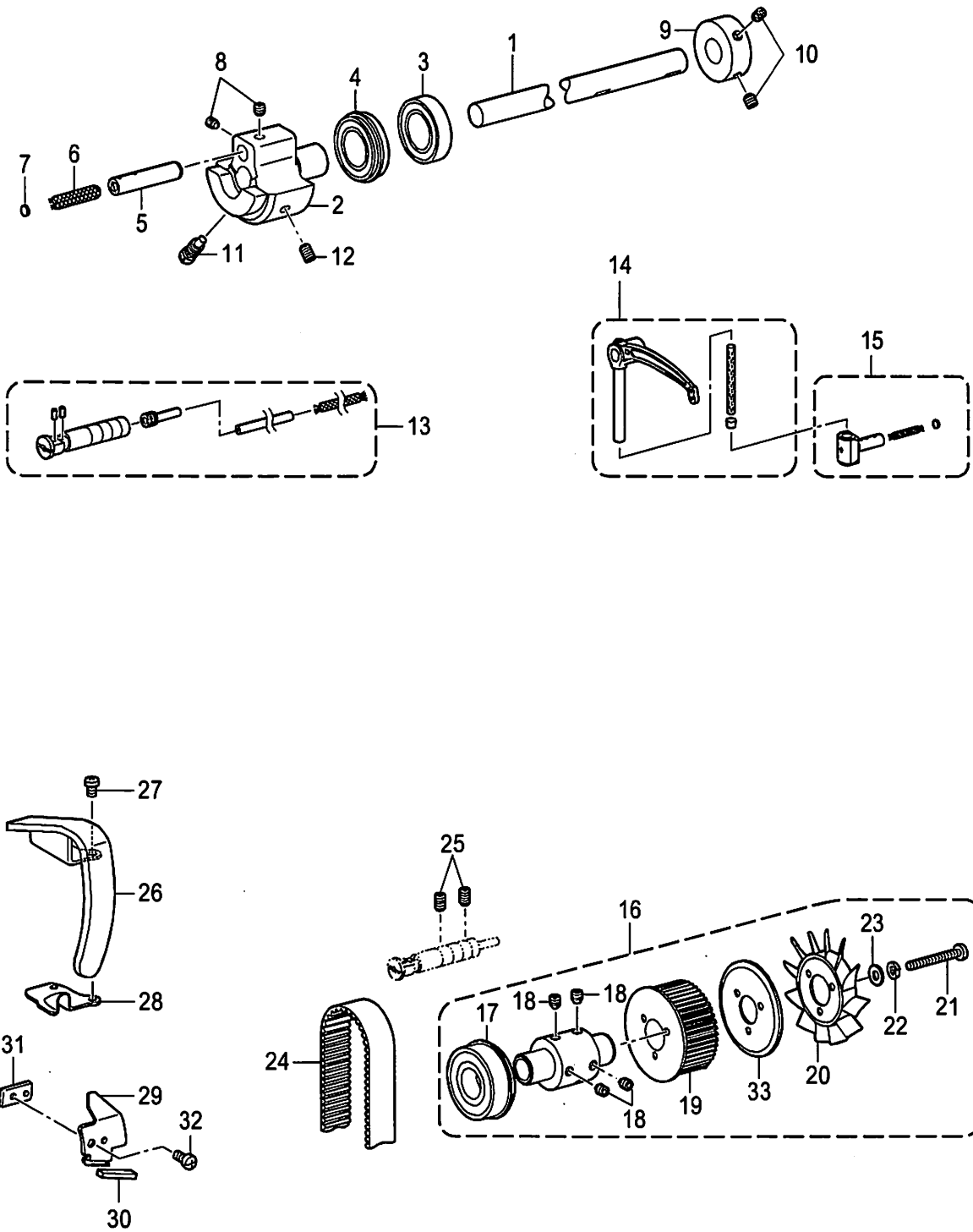

from the library of Diamond Needle Corp

B . 上軸関係 / Upper shaft mechanism

REF.NO	CODE	Q'TY	品名	NAME OF PARTS	RM
1	SA4551001	1	ウワジクDD	UPPER SHAFT, DD	
2	SA4373001	1	テンピンクランク	THREAD TAKE-UP CRANK	
3	S25234001	1	タマジクウケ6004ZZ	BALL BEARING, 6004ZZ	
4	S38707001	1	タマジクウケ6004ZZNR	BALL BEARING, 6004ZZNR	
5	SA6166001	1	ハリボウクランクジク	CRANKSHAFT	
6	117006001	1	クミヒモ	WICK, L=60	
7	113014000	1	クミヒモフタ	PUSHER	
8	S25260001	2	アナヒラ6X5ホソメ	SET SCREW, SOCKET (FT) M6X5	
9	SA1120001	1	イトマキドウリン	BOBBIN WINDER DRIVING WHEEL	
10	S23651001	2	アナヒラ6X6ホソメ	SET SCREW, SOCKET (FT) M6X6	
11	S25235001	1	シメネジ8	SCREW, M8	
12	S25236001	1	アナヒラ6X10ホソメ	SET SCREW, SOCKET (FT) M6X10	
13	SA2861101	1	テンピンササエジクソウクミ	THREAD TAKE-UP S-SHAFT UNIT	
14	SA2935101	1	テンピンS3-Lクミ	THREAD TAKE-UP LEVER ASSY,S3-L	
15	S13160001	1	テンピンスベリコ2クミ	T-TAKE-UP SLIDE BLOCK ASSY,2	
16	SA2460001	1	ツギテソウクミ	PRESSER ADJUSTING UNIT	
17	S38710001	1	タマジクウケ6204ZZNR	BALL BEARING, 6204ZZNR	
18	S23651001	4	アナヒラ6X6ホソメ	SET SCREW, SOCKET (FT) M6X6	
19	SA2461001	1	タイミングプーリU DD	TIMING PULLEY, U DD	
20	S38713100	1	ファン	FAN	
21	062403512	3	ナベコ4X35	SCREW, PAN M4X35	
22	028040242	3	パネザガネ2-4	WASHER, SPRING 2-4	
23	025040232	3	ヒラザガネチユウ4	WASHER, PLAIN M 4	
24	SA2463001	1	タイミングベルト	TIMING BELT	
25	012061036	2	アナヒラ6X10	SET SCREW, SOCKET (FT) M6X10	
26	SA2469001	1	テンピンカバー	THREAD TAKE-UP LEVER COVER	
27	062500816	2	ナベコ5X8	SCREW, PAN M5X8	
28	SA3057001	1	ダストカバー	DUST COVER	
29	SA4376101	1	シヤヘイバン	SHELTER PLATE	
30	SA3065001	1	フェルト	FELT	
31	SA3059001	1	シヤヘイバンオサエ	HOLDER, SHELTER PLATE	
32	062500816	1	ナベコ5X8	SCREW, PAN M5X8	
33	SA2462001	1	プーリUフランジ	PULLEY U FLANGE	

C . 針棒搖動關係 / Needle bar rocking mechanism

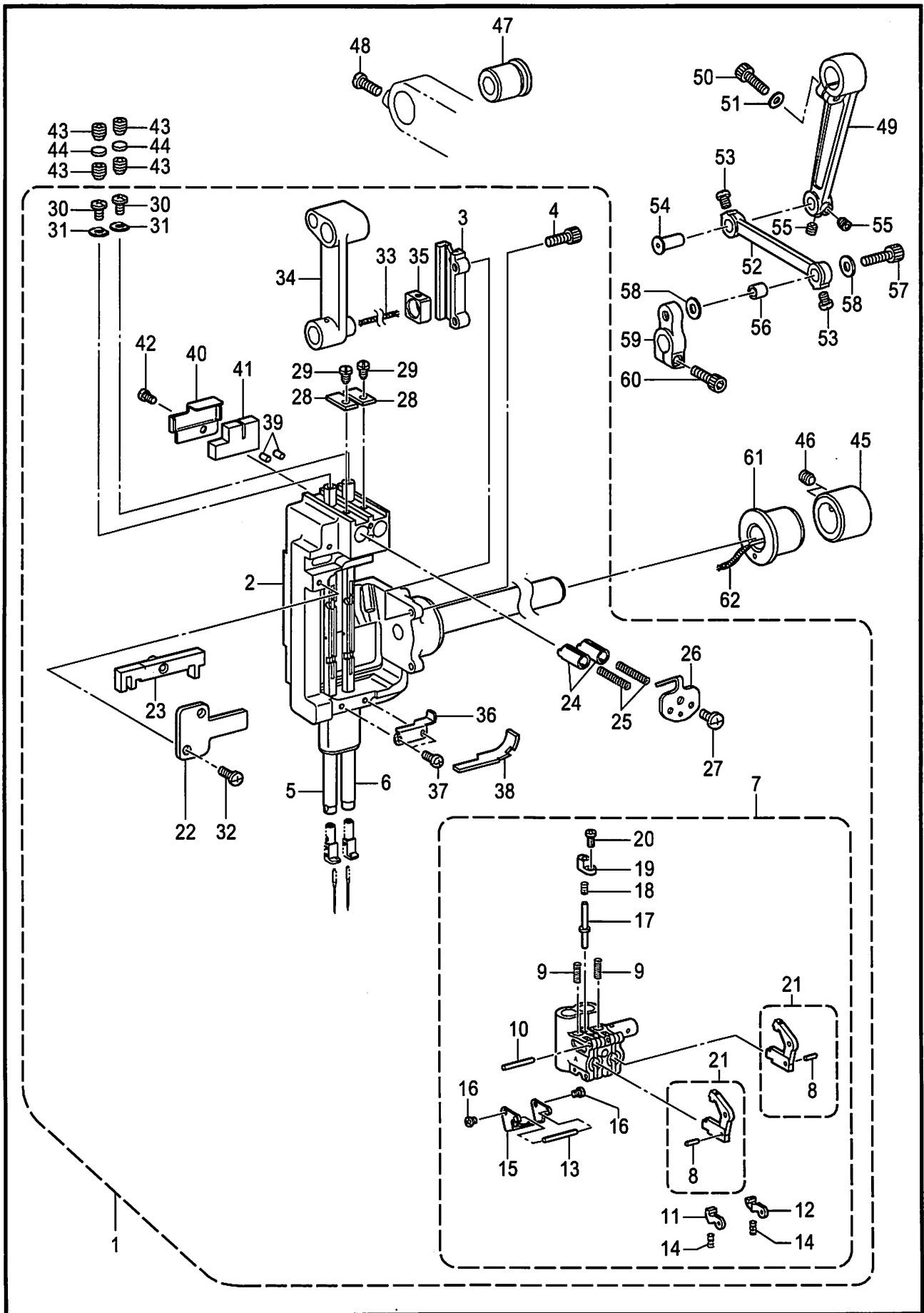

from the library of Diamond Needle Corp

C. 針棒揺動関係 / Needle bar rocking mechanism

REF.NO	CODE	Q'TY	品名	NAME OF PARTS	RM
1	SA4377001	1	ハリボウヨウドウジクミ	NEEDLE BAR ROCKER SHAFT ASSY	
2	SA4378001	1	ハリボウダイクミ	NEEDLE BAR BASE ASSY	
3	SA2474201	1	カクコマスライダ	SLIDE BLOCK SLIDER	
4	018401036	2	アナボルト4X10	BOLT SOCKET M4X10	
5	SA4382001	1	ハリボウLクミ	NEEDLE BAR ASSY, L	
6	SA4385001	1	ハリボウRクミ	NEEDLE BAR ASSY, R	
			必ず記号を確認後注文のこと	Need check the "Mark" the following parts before ordering.	
7	SA4387001	1	ハリボウダキクミ <記号A>	NEEDLE BAR CLAMP ASSY <Mark A>	
7	SA4387002	1	ハリボウダキクミ <記号B>	NEEDLE BAR CLAMP ASSY <Mark B>	
7	SA4387003	1	ハリボウダキクミ <記号C>	NEEDLE BAR CLAMP ASSY <Mark C>	
8	149604001	2	ピン1.5X5.8	PIN, 1.5X5.8	
9	149605001	2	クラツチテコバネ	SPRING, CLUTCH LEVER	
10	149827001	1	ピン2X15.8	PIN, 2X15.8	
11	S34561001	1	クラツチトメL	CLUTCH STOPPER, L	
12	S34562001	1	クラツチトメR	CLUTCH STOPPER, R	
13	149608001	1	ピン2X17.8	PIN, 2X17.8	
14	112609001	2	スベリイタストツババネ	SPRING	
15	SA4391001	1	バネササエ	SPRING HOLDER	
16	062260316	2	ナベコ26X3	SCREW PAN M2.6X3	
17	149610001	1	リリースピン	PIN	
18	149611101	1	リリースピンバネ	SPRING, RELEASE PIN	
19	SA4392001	1	リリースピンフタ	PIN COVER	
20	062260516	1	ナベコ26X5	SCREW PAN M2.6X5	
21	SA4389001	2	クラツチテコクミ	CLUTCH LEVER ASSY	
22	SA4395001	1	スベリコアンナイイタ	SLIDE BLOCK GUIDE PLATE	
			必ず記号を確認後注文のこと	Need check the "Mark" the following parts before ordering.	
23	S07575000	1	スベリコクミ <記号25>	SLIDE BLOCK ASSY, 25 <Mark 25>	
23	S07575001	1	スベリコクミ <記号30>	SLIDE BLOCK ASSY, 30 <Mark 30>	
23	S07575002	1	スベリコクミ <記号35>	SLIDE BLOCK ASSY, 35 <Mark 35>	
23	S07575003	1	スベリコクミ <記号40>	SLIDE BLOCK ASSY, 40 <Mark 40>	
23	S07575004	1	スベリコクミ <記号45>	SLIDE BLOCK ASSY, 45 <Mark 45>	
23	S07575005	1	スベリコクミ <記号50>	SLIDE BLOCK ASSY, 50 <Mark 50>	
23	S07575006	1	スベリコクミ <記号55>	SLIDE BLOCK ASSY, 55 <Mark 55>	
23	S07575007	1	スベリコクミ <記号60>	SLIDE BLOCK ASSY, 60 <Mark 60>	
23	S07575008	1	スベリコクミ <記号65>	SLIDE BLOCK ASSY, 65 <Mark 65>	
23	S07575009	1	スベリコクミ <記号70>	SLIDE BLOCK ASSY, 70 <Mark 70>	
23	S07575010	1	スベリコクミ <記号75>	SLIDE BLOCK ASSY, 75 <Mark 75>	
23	S07575011	1	スベリコクミ <記号80>	SLIDE BLOCK ASSY, 80 <Mark 80>	
24	SA4583001	2	ハリボウストツパー	STOPPER, N-BAR	
25	149622001	2	ハリボウストツパーバネ	SPRING, N-BAR STOPPER	
26	SA4396001	1	バネフタ	SPRING COVER	
27	060350616	1	バインド35X6	SCREW BIND M3.5X6	
28	SA4397001	2	ハリボウマワリトメ	ROTATE STOPPER, N-BAR	
29	SA4398001	2	シメネジ3.5	SCREW, SM3.5	
30	060350616	2	バインド35X6	SCREW BIND M3.5X6	
31	SA4399001	2	ザガネ	WASHER, PLANE	
32	062350816	2	ナベコ35X8	SCREW PAN M3.5X8	
33	112728001	1	クミヒモ	WICK, L=50	
34	SA4393001	1	ハリボウクランクロツド	CRANK ROD, N-BAR	
35	SA4394001	1	カクコマ	SLIDE BLOCK	
36	SA4401001	1	フェルトオサエD	FELT SUPPORT, D	
37	062350516	2	ナベコ35X5	SCREW PAN M3.5X5	
38	SA4400001	1	フェルト	FELT	
39	107155001	2	フェルト	FELT	
40	SA5155001	1	フェルトササエ	FELT SUPPORT	

C. 針棒搖動關係 / Needle bar rocking mechanism

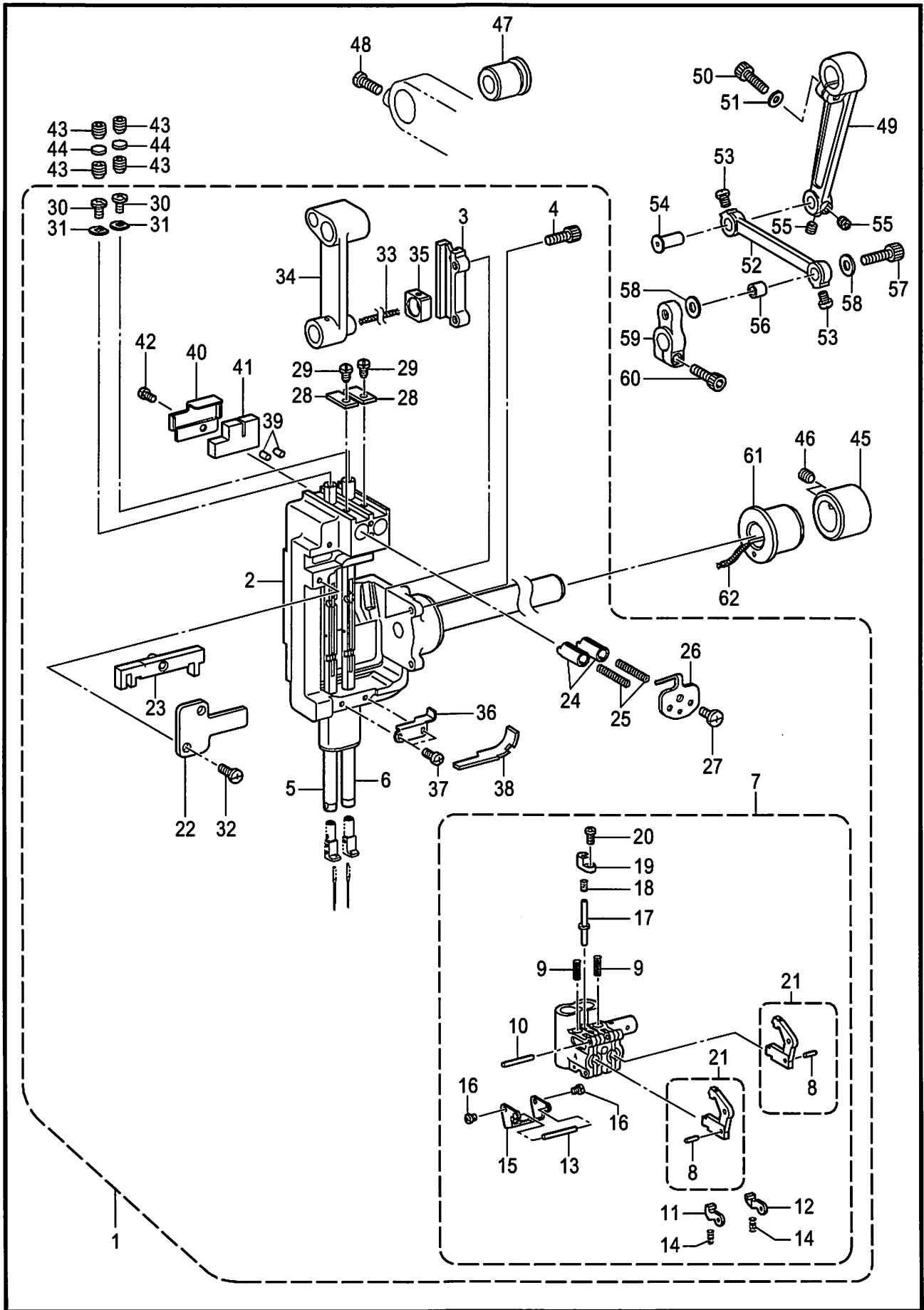

from the library of Diamond Needle Corp

C. 針棒揺動関係 / Needle bar rocking mechanism

REF.NO	CODE	Q'TY	品名	NAME OF PARTS	RM
41	SA5237101	1	フェルト	FELT	
42	062350516	1	ナベコ35X5	SCREW PAN M3.5X5	
43	014080831	4	アナクボミ8X8	SET SCREW SOCKET (CP) M8X8	
44	154567000	2	カンザ5.3	SPACER, 5.3	
45	SA2485001	1	セットカラー	SET SCREW COLLAR	
46	S25260001	2	アナヒラ6X5ホソメ	SET SCREW, SOCKET (FT) M6X5	
47	SA2486101	1	ヨウドウジクメタルR	BUSH, R	
48	062061616	1	ナベコ6X16	SCREW PAN M6X16	
49	SA2489001	1	ハリボウヨウドウレバー	NEEDLE BAR ROCKER LEVER ASSY	
50	018062032	1	アナボルト6X20	BOLT SOCKET M6X20	
51	118735002	1	ザガネ	WASHER	
52	SA2490101	1	ハリボウヨウドウリンク	ROCKER LINK, N-BAR	
53	S23460001	2	ナベコ6X5	SCREW, PAN M6X5	
54	SA4117001	1	ヨウドウリンクジクP	LINK SHAFT, N-BAR ROCKER P	
55	012060636	2	アナヒラ6X6	SET SCREW SOCKET (FT) M6X6	
56	SA4118001	1	ヨウドウリンクカラ-P	ZIGZAG LINK BUSH, P	
57	018062532	1	アナボルト6X25	BOLT SOCKET M6X25	
58	SA2493001	2	ザガネ	WASHER, PLAIN	
59	SA2494001	1	ハリボウヨウドウウデ	NEEDLE BAR ROCK ARM	
60	018062032	1	アナボルト6X20	BOLT SOCKET M6X20	
61	SA5332001	1	ヨウドウジクメタルL	BUSH, L	
62	S48204000	1	クミヒモ4X4	WICK, 4X4 L=150	

D. 針棒切換操作關係 / Needle bar flip-up mechanism

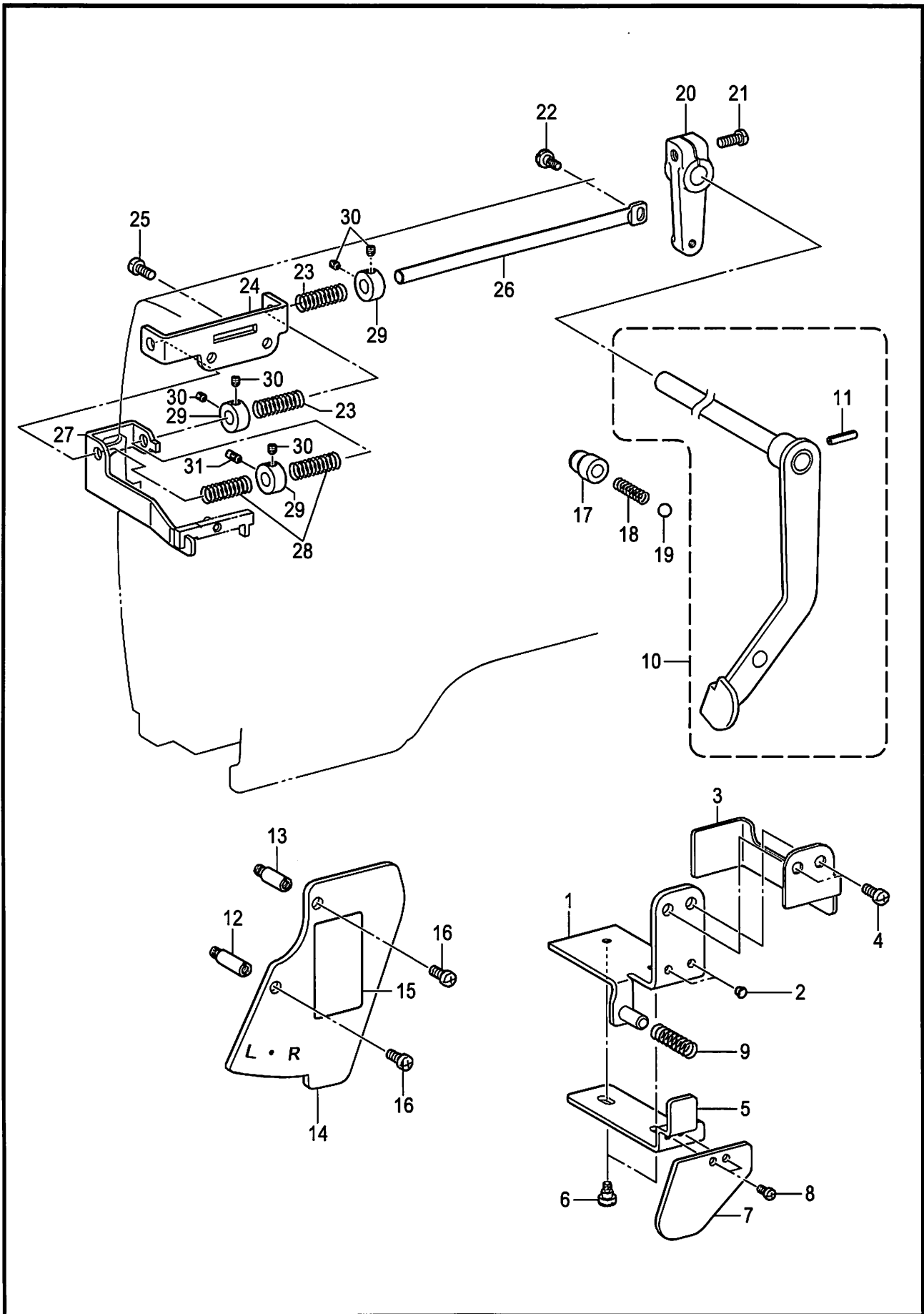

from the library of Diamond Needle Corp

D. 針棒切替操作関係 / Needle bar flip-up mechanism

REF.NO	CODE	QTY	品名	NAME OF PARTS	RM
1	SA4402001	1	シジイタクミ	INDICATION PLATE ASSY	
2	104833001	2	ゴムセン4.3	RUBBER CAP, 4.3	
3	SA5336001	1	シジイタカバー	HOLDER PLATE COVER	
4	062501016	2	ナベコ5X10	SCREW PAN M5X10	
5	SA4404001	1	プツシユレバー	PUSH LEVER	
6	SA4441001	2	ダンネジM4	SHOULDER SCREW, M4	
7	SA4405001	1	プツシユレバーイタ	PLATE, PUSH LEVER	
8	062350516	2	ナベコ35X5	SCREW PAN M3.5X5	
9	SA5333001	1	プツシユレバーバネ	SPRING	
10	SA4406001	1	ストップレバージククミ	STOP LEVER SHAFT ASSY	
11	047301842	1	スプリングピンAW3	PIN SPRING ROLL AW3	
12	SA4408001	1	スタツドL	STUD, L	
13	SA4409001	1	スタツドS	STUD, S	
14	SA4411101	1	キリカエシジイタ	FLIP-UP HOLDER PLATE	
15	S18964001	1	<日本向用> キリカエシジイタラベル.ワイ	<For Japan only> LABEL	
15	SA4419001	1	<日本向以外用> キリカエシジイタラベル.チュウエイ	<For Except Japan> LABEL	
16	062500816	2	ナベコ5X8	SCREW PAN M5X8	
17	SA4412001	1	タマアンナイプツシユ	BALL GUIDE BUSH	
18	150820001	1	タマオシバネ	SPRING	
19	071063550	1	コウキユウ1/4	BEARING BALL, 1/4	
20	SA4413001	1	レバージクウデ	ARM, LEVER SHAFT	
21	062501416	1	ナベコ5X14	SCREW PAN M5X14	
22	SA5588001	1	ダンネジM4	SHOULDER SCREW M4	
23	SA4414001	2	レバージクウデバネ	SPRING	
24	SA4415001	1	スライドジクウケ	SLIDE SHAFT BRACKET	
25	062500816	2	ナベコ5X8	SCREW PAN M5X8	
26	S07588101	1	スライドジク	SLIDE SHAFT	
27	SA4416001	1	スライドジクウケイタ	SUPPORT PLATE, SLIDE SHAFT	
28	149863001	2	ジクウケイタバネ	SPRING, PLATE	
29	SA4417001	3	セツトカラー	SET SCREW COLLAR	
30	014400432	5	アナクボミ4X4	SET SCREW SOCKET (CP) M4X4	
31	SA4418001	1	アンナイネジ	GUIDE SCREW	

E . 押え関係 / Presser foot mechanism

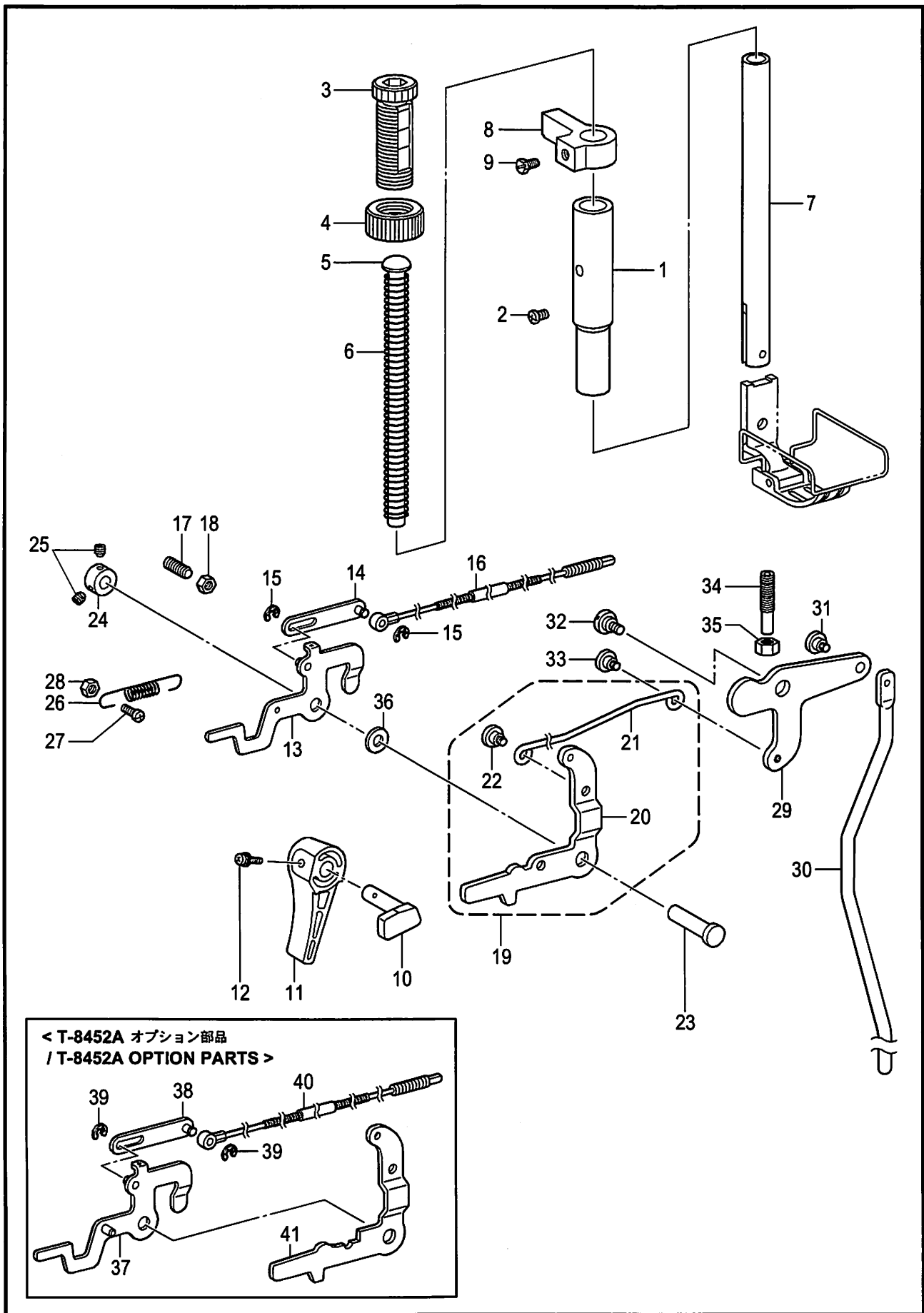

E . 押え関係 / Presser foot mechanism

REF.NO	CODE	Q'TY	品名	NAME OF PARTS	RM
1	SA2495001	1	オサエボウメタル	PRESSER BAR BUSH	
2	062500816	1	ナベコ5X8	SCREW, PAN M5X8	
3	SA1174001	1	オサエチヨウセツネジM14	PRESSER ADJUSTING SCREW, M14	
4	SA1175001	1	チヨウセツネジナツトM14	ADJUST SCREW NUT	
5	141208001	1	オサエパネアンナイ	SPRING GUIDE	
6	S07346101	1	オサエパネ	PRESSER BAR SPRING, -5	
7	SA2496001	1	オサエボウ	PRESSER BAR	
8	SA2498001	1	オサエボウダキ	GUIDE BRACKET, P-BAR	
9	S25289001	1	ボルト6	BOLT, (CP) M6X10	
10	SA2499001	1	オサエアゲケランク	PRESSER BAR LIFTING CRANK	
11	S31006001	1	オサエアゲテコ	LIFTING LEVER	
12	S39051001	1	ナベザクミ35X12	SCREW, PAN (S/P W) M3.5X12	
13	S07351001	1	イトユルメイタクミ	TENSION RELEASE PLATE ASSY	
14	S07529001	1	イトユルメレンカンクミ	T-RELEASE CONNECTING ROD ASSY	
15	048030342	2	トメワE3	RETAINING RING, E3	
16	SA2677001	1	イトユルメワイヤー	TENSION RELEASE WIRE	
17	012061832	1	アナヒラ6X18	SET SCREW, SOCKET (FT) M6X18	
18	021060306	1	3シユナツト6	NUT, 3 M6	
19	SA2500001	1	ヒザアゲレンカンクミ	KNEE LIFTER C-ROD ASSY	
20	SA2501001	1	オサエアゲレバー	PRESSER BAR LIFTING LEVER	
21	SA2502001	1	ヒザアゲレンカン	KNEE LIFTER CONNECTING ROD	
22	SA1179001	1	ダンネジ5	SHOULDER SCREW, M5	
23	S07349001	1	オサエアゲレバージク	P-BAR LIFTING LEVER SHAFT	
24	SA2504001	1	セットカラ-	SET SCREW COLLAR	
25	012500536	2	アナヒラ5X5	SET SCREW, SOCKET (FT) M5X5	
26	S07355051	2	オサエアゲレバーパネ	SPRING, EXTENSION	
27	062501416	1	ナベコ5X14	SCREW, PAN M5X14	
28	021500106	1	1シユナツト5	NUT, 1 M5	
29	SA2506001	1	ヒザアゲレバー	KNEE LIFTER LEVER	
30	SA2507001	1	ヒザアゲボウ	KNEE LIFTER BAR	
31	SA1179001	1	ダンネジ5	SHOULDER SCREW, M5	
32	SA2165001	1	ダンネジ6	SHOULDER SCREW, M6	
33	SA1179001	1	ダンネジ5	SHOULDER SCREW, M5	
34	SA4149101	1	チヨウセツネジ6	ADJUSTING SCREW 6	
35	021060306	1	3シユナツト6	NUT, 3 M6	
36	S07350001	1	ザガネ	WASHER, PLAIN	
			< T-8452A オプション部品 >	< T-8452A OPTION PARTS >	
37	S10780001	1	イトユルメイタクミ	TENSION RELEASE PLATE ASSY	
38	S07529001	1	イトユルメレンカンクミ	T-RELEASE CONNECTING ROD ASSY	
39	048030342	2	トメワE3	RETAINING RING, E3	
40	SA2677001	1	イトユルメワイヤー	TENSION RELEASE WIRE	
41	SA2578001	1	オサエアゲレバー	PRESSER BAR LIFTING LEVER	

F. 送り関係 / Feed mechanism

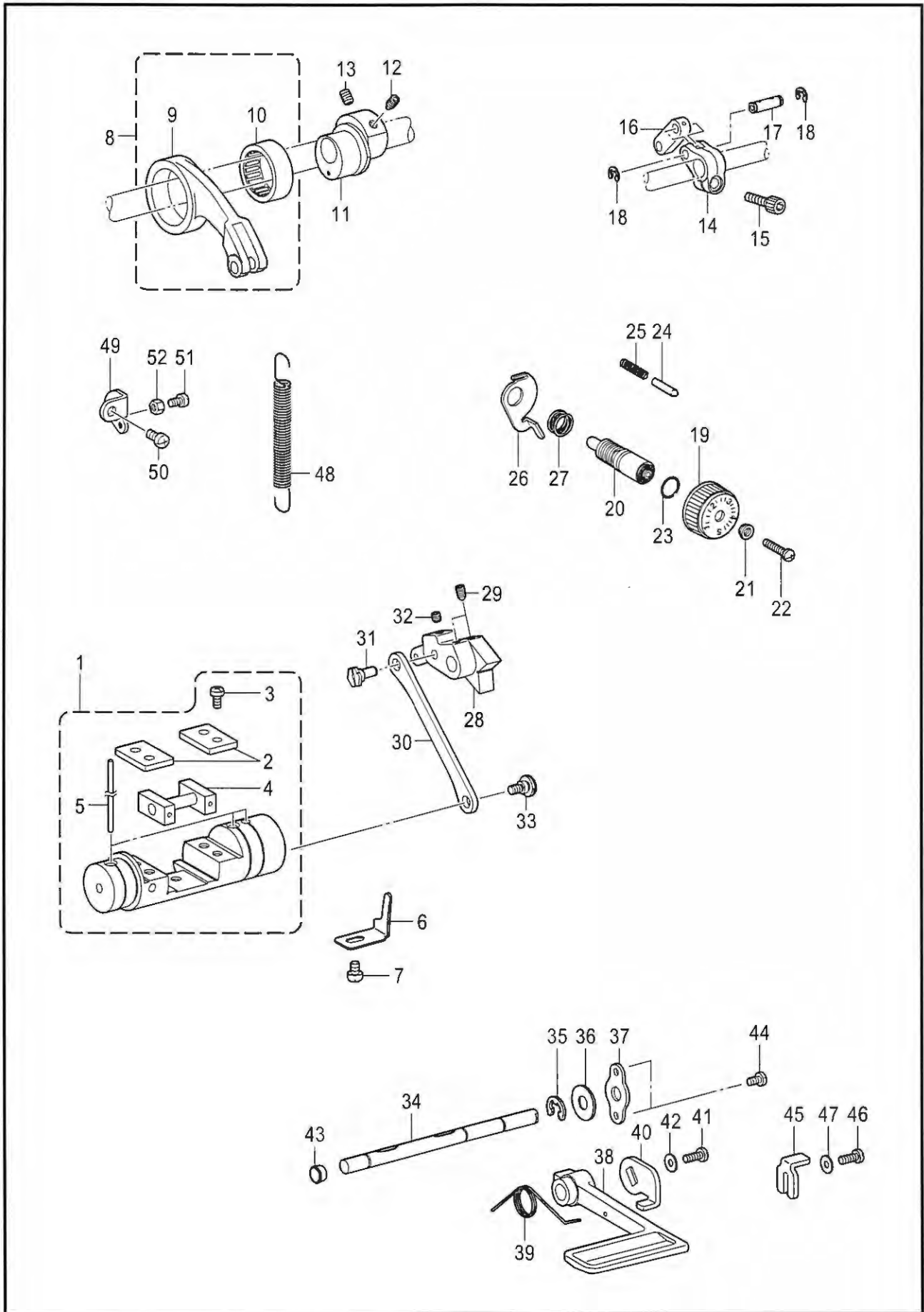

from the library of Diamond Needle Corp

F . 送り関係 / Feed mechanism

REF.NO	CODE	QTY	品名	NAME OF PARTS	RM
1	SA2509001	1	キリカエキクミ	FEED REGULATOR ASSY	
2	SA2511001	2	カクコマアンナイタ	GUIDE PLATE	
3	062501016	4	ナベコ5X10	SCREW, PAN M5X10	
4	SA2512001	1	キリカエキカクコマクミ	SLIDE BLOCK ASSY	
5	SA2515001	3	フェルト	FELT	
6	SA2516001	1	キリカエキトメ	STOPEER	
7	062060816	1	ナベコ6X8	SCREW, PAN M6X8	
8	143611201	1	スイヘイオクリレンカンクミ	F-ROCKER CONNECTING ROD ASSY	
9	143612100	1	スイヘイオクリレンカン	FEED ROCKER CONNECTING ROD	
10	118954000	1	ニードルベアリング	NEEDLE BEARING	
11	SA2518001	1	スイヘイヘンシンリン5	LEVEL FEED ECCENTRIC WHEEL 5	
12	SA2585001	1	アナトガリ6X10ホソメ	SET SCREW, SOCKET (FT) M6	
13	S25236001	1	アナヒラ6X10ホソメ	SET SCREW, SOCKET (FT) M6X10	
14	SA2521001	1	スイヘイオクリウデ5	FEED ROCKER ARM 5	
15	018062032	1	アナボルト6X20	BOLT, SOCKET M6X20	
16	143613051	1	スイヘイオクリウデリンク	LINK	
17	143616001	1	スイヘイオクリウデジク	SHAFT	
18	048060342	2	トメフE6	RETAINING RING, E6	
19	S38427001	1	オクリメモリダイヤル	STITCH LENGTH DIAL, 5	
20	SA3056001	1	オクリチヨウセツネジ	FEED REGULATING STUD	
21	142746002	1	メモリイタオサエ	FEED REGULATING SUPPORTER	
22	129458102	1	シメネジ4.76	SCREW, SM4.76	
23	108549001	1	Oリング	O RING	
24	S50098101	1	メモリイチギメピン	POSITIONING PIN	
25	100328001	1	メモリイチキメピンバネ	NOTCH SPRING	
26	SA2523001	1	ダイヤルロックレバー	DIAL LOCK LEVER	
27	S39830101	1	ダイヤルロックレバーバネ	SPRING	
28	SA2525001	1	オクリチヨウセツキ5	FEED REGULATOR 5	
29	016061031	2	アナトガリ6X10	SET SCREW, SOCKET (CN) M6X10	
30	SA2526001	1	キリカエキレンカン	CONNECTING ROD	
31	SA2527001	1	ヘンシンジク	ECCENTRIC SHAFT	
32	012060636	1	アナヒラ6X6	SET SCREW, SOCKET (FT) M6X6	
33	SA2528101	1	ダンネジ6	SHOULDER SCREW, M6	
34	SA2529101	1	カエシヌイレバージクTR	SHAFT, R-LEVER TR	
35	048080342	1	トメフE8	RETAINING RING, E8	
36	025100132	1	ヒラザガネシヨウ10	WASHER, PLAIN S 10	
37	SA2530001	1	カンザ	SPACER	
38	S07374109	1	カエシヌイレバー	REVERSE STITCHING LEVER	
39	SA2531001	1	カエシヌイレバーオサエバネ	SPRING	
40	SA2541001	1	カエシヌイレバーイタ	REVERSE STITCHING LEVER PLATE	
41	062501216	1	ナベコ5X12	SCREW, PAN M5X12	
42	025050336	1	ヒラザガネダイ5	WASHER, PLAIN L 5	
43	104821001	1	ゴムセン10.5	RUBBER CAP, 10.5	
44	062500816	2	ナベコ5X8	SCREW, PAN M5X8	
45	SA2532001	1	ハンドルストツパ	STOPPER	
46	062501216	1	ナベコ5X12	SCREW, PAN M5X12	
47	025050236	1	ヒラザガネチュウ5	WASHER, PLAIN M 5	
48	S07376001	1	キリカエキバネ	FEED REGULATOR SPRING	
49	SA2533001	1	バネカケ	SPRING HOOK	
50	062060816	1	ナベコ6X8	SCREW, PAN M6X8	
51	062501216	1	ナベコ5X12	SCREW, PAN M5X12	
52	021500106	1	1シユナツト5	NUT, 1 M5	

G. 逆転関係 / Quick reverse mechanism

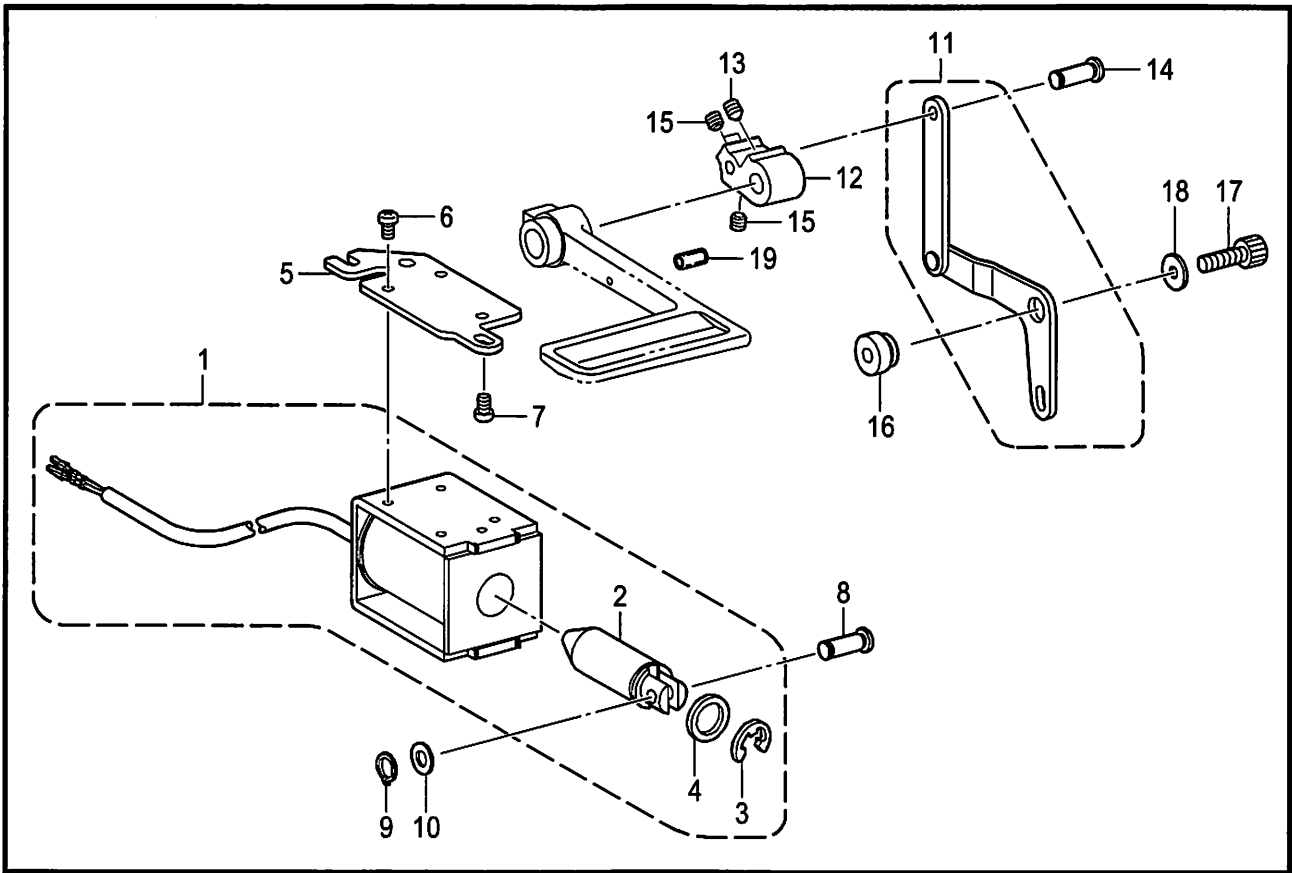

T-8452A-205

H. 逆転スイッチ関係 / Quick reverse switch mechanism

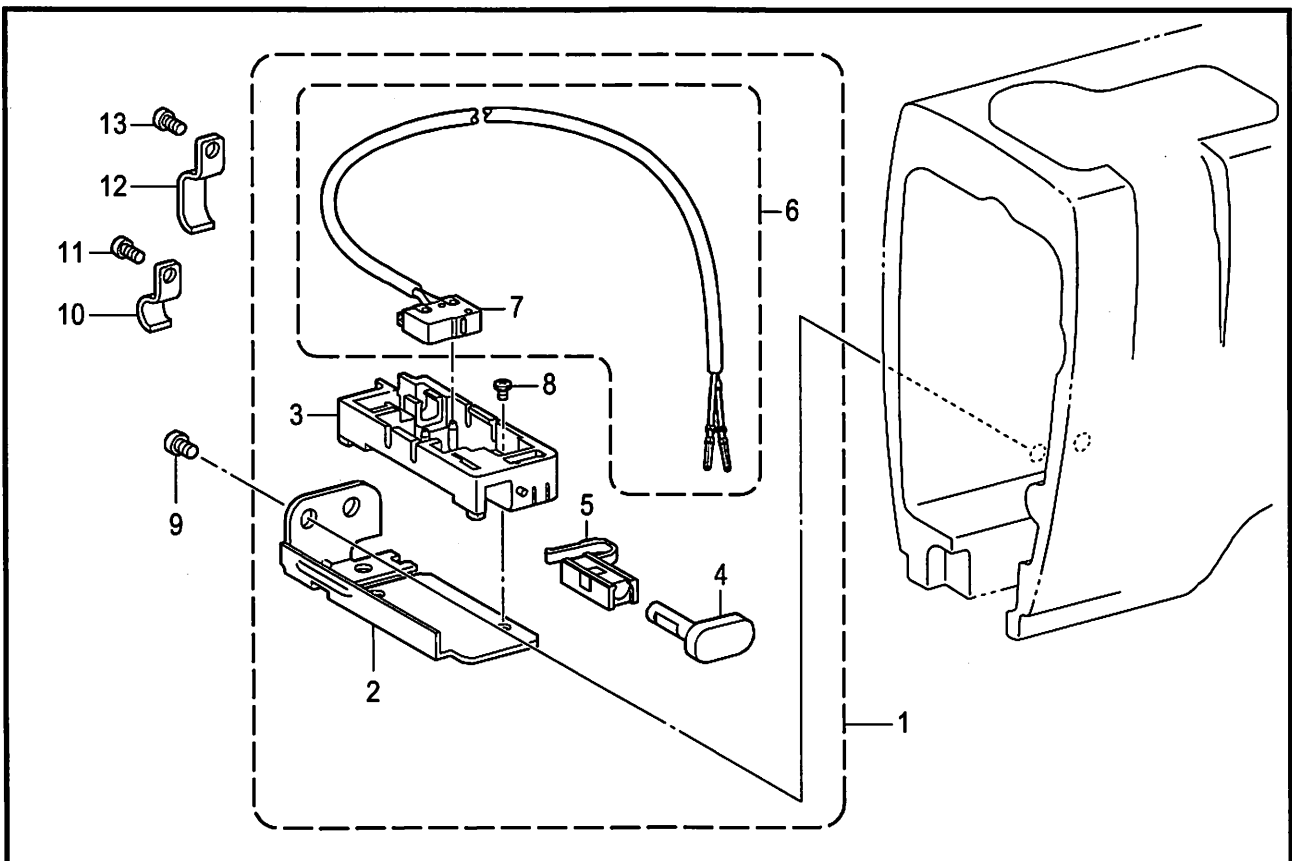

T-8452A-508

G . 逆転関係 / Quick reverse mechanism

REF.NO	CODE	Q'TY	品名	NAME OF PARTS	RM
1	SA3072001	1	ギヤクテンソレノイドクミ	QUICK REVERSE SOLENOID ASSY	
2	154729001	1	プランジャ	PLUNGER	
3	154730001	1	トメワE15	RETAINING RING, E15	
4	154731000	1	ゴムストツパー	RUBBER STOPPER	
5	SA2535101	1	ソレノイドドダイ	SOLENOID BRACKET	
6	062500812	3	ナベコ5X8	SCREW, PAN M5X8	
7	062061016	2	ナベコ6X10	SCREW, PAN M6X10	
8	SA2992001	1	レンケツピン	PIN	
9	048060142	1	トメワジクヨウC6	RETAINING RING, EXTERNAL C6	
10	153138001	1	ザガネ	WASHER, PLAIN 6.5	
11	SA2536001	1	ソレノイドレバークミ	SOLENOID LEVER ASSY	
12	SA2540001	1	ギヤクテンレバー	QUICK REVERSE LEVER	
13	016061031	2	アナガリ6X10	SET SCREW, SOCKET (CN) M6X10	
14	SA2992001	1	レンケツピン	PIN	
15	012060636	2	アナヒラ6X6	SET SCREW, SOCKET (FT) M6X6	
16	SA2539001	1	ソレノイドレバークミ	SOLENOID LEVER SHAFT	
17	018062032	1	アナボルト6X20	BOLT, SOCKET M6X20	
18	149095001	1	ザガネ	WASHER, PLAIN 6	
19	153132000	1	ナイロンチューブ	NYLON TUBE, L=13.5	

T-8452A-205

H . 逆転スイッチ関係 / Quick reverse switch mechanism

REF.NO	CODE	Q'TY	品名	NAME OF PARTS	RM
1	SA2688001	1	Rアクチュエータークミ	REVERSE ACTUATOR ASSY	
2	SA2270001	1	Rスイッチササエ	REVERSE SWITCH BRACKET	
3	S34281000	1	Rスイッチダイ	REVERSE SWITCH BRACKET	
4	S32904000	1	アクチュエーター	ACTUATOR	
5	S32905000	1	Rスイッチパネ	REVERSE SWITCH SPRING	
6	SA1390001	1	Rスイッチクミ	R-SWITCH ASSY	
7	S32907000	1	マイクロスイッチ	MICRO SWITCH	
8	060300606	1	バインド3X6	SCREW, BIND M3X6	
9	062500616	2	ナベコ5X6	SCREW, PAN M5X6	
10	SA2689001	1	コードオサエ	CORD HOLDER	
11	062500616	1	ナベコ5X6	SCREW, PAN M5X6	
12	SA1388001	3	コードオサエ	CORD HOLDER	
13	062500616	1	ナベコ5X6	SCREW, PAN M5X6	

T-8452A-508

J. 送り軸関係 / Feed shaft mechanism

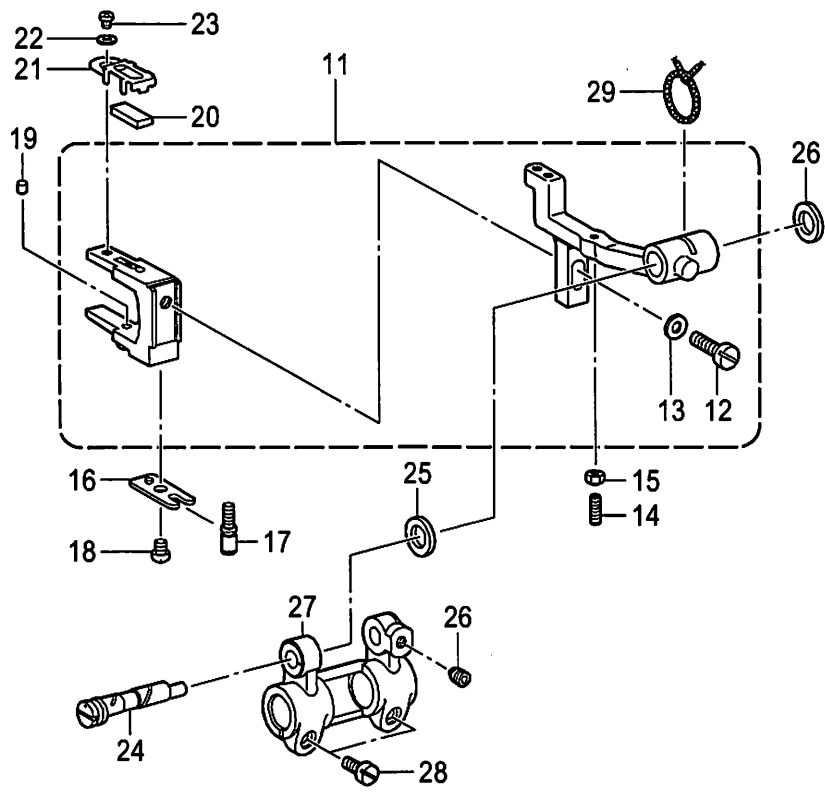
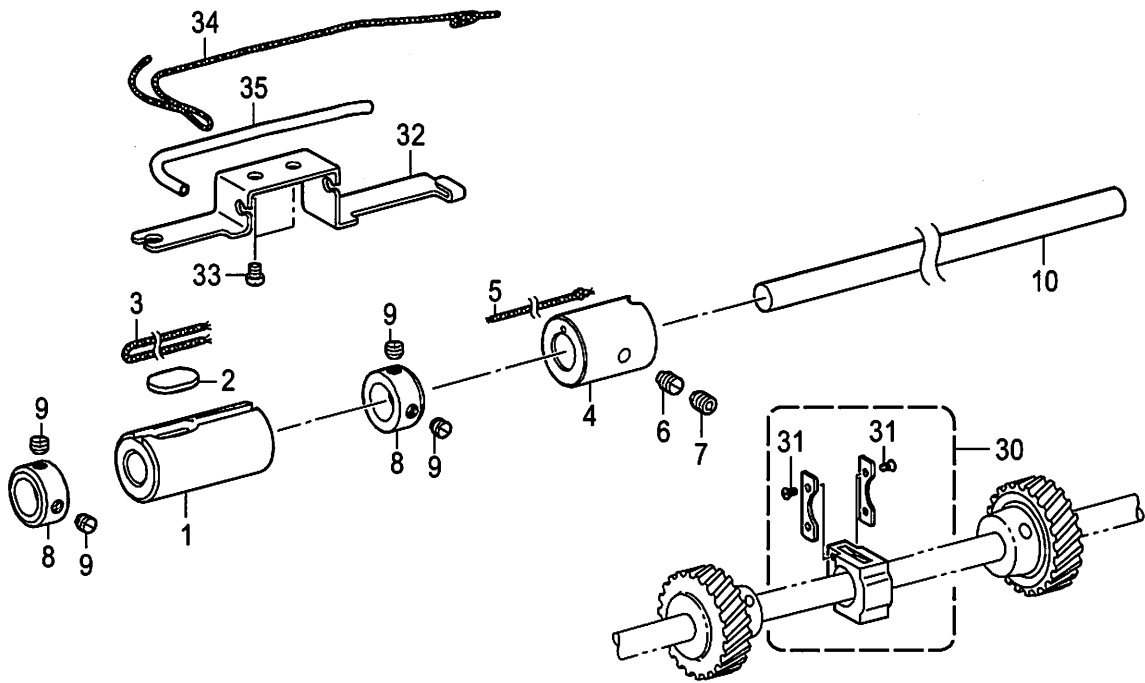

from the library of Diamond Needle Corp

J . 送り軸関係 / Feed shaft mechanism

REF.NO	CODE	Q'TY	品名	NAME OF PARTS	RM
1	SA3855001	1	オクリジクメタルL	BUSH,L:F-ROCKER SHAFT	
2	SA3965001	1	フェルト	FELT	
3	SA4028001	1	クミヒモ4X4 L=220	WICK, 4X4 L=220	
4	SA2543001	1	オクリジクメタルR	FEED ROCKER SHAFT BUSH, R	
5	108802001	1	クミヒモ4X4	WICK, 4X4 L=250	
6	SA2544001	1	トメネジM6	SET SCREW M6	
7	012060636	1	アナヒラ6X6	SET SCREW, SOCKET (FT) M6X6	
8	SA2546001	2	セツトカラー	SET SCREW COLLAR	
9	S23651001	4	アナヒラ6X6ホソメ	SET SCREW, SOCKET (FT) M6X6	
10	SA3840001	1	スイヘイオクリジク	FEED ROCKER SHAFT	
11	SA6150001	1	オクリダイTRフタマタクミ	FEED BAR TR FORK ASSY	
12	SA2927001	1	シメネジM6X14	SCREW, M6X14	
13	025060132	1	ヒラザガネシヨウ6	WASHER, PLAIN S 6	
14	SA2566001	1	トメネジ3.5	SET SCREW, M3.5	
15	021350106	1	1シュナツト35	NUT, 1 M3.5	
16	SA2553001	1	フタマタプレート	FORKED PLATE	
17	SA2554001	1	タカサチヨウセツネジ	ADJUSTING SCREW ,HIGHT	
18	062400616	1	ナベコ4X6	SCREW, PAN M4X6	
19	SA3990001	1	フェルト	FELT	
20	SA3887001	1	フェルト	FELT	
21	SA3888001	1	フェルトオサエ	FELT HOLDER	
22	025030132	1	ヒラザガネシヨウ3	WASHER, PLAIN S 3	
23	062300416	1	ナベコ3X4	SCREW, PAN M3X4	
24	SA2550001	1	オクリダイトリツケジク	FEED BAR SHAFT	
25	SA2551001	2	スラストリング	THRUST RING	
26	012060636	1	アナヒラ6X6	SET SCREW, SOCKET (FT) M6X6	
27	SA2555001	1	スイヘイオクリダイウデ	FEED ROCKER BASE ARM	
28	SA2928001	2	シメネジM5X12	SCREW, M5X12	
29	SA4538001	1	クミヒモ3X3 L=200	WICK, 3X3 L=200	
30	SA2806001	1	オクリダイカクコマクミ	FEED BAR SLIDE BLOCK ASSY	
31	W01519001	4	0サラコ3シユ2X4	SCREW, FLAT #0 M2X4	
32	SA4009001	1	クミヒモササエ	WICK SUPPORT	
33	062400616	2	ナベコ4X6	SCREW, PAN M4X6	
34	SA2724001	1	クミヒモ	WICK, L=400	
35	SA4011001	1	ビニルチューブ L=100	OIL TUBE, L=100	

K1 . かま関係 / Rotary hook mechanism

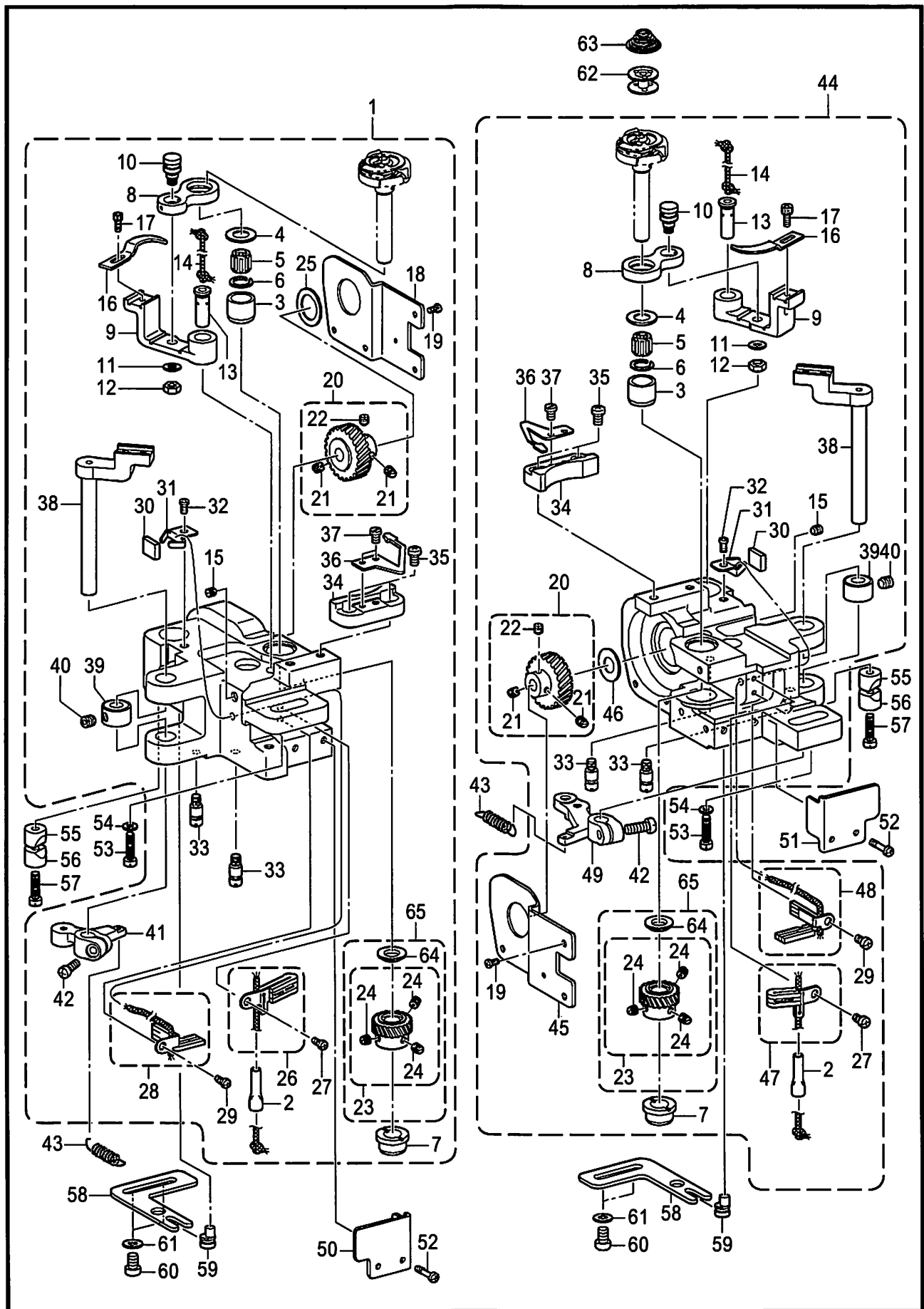

from the library of Diamond Needle Corp

K1 . かま関係 / Rotary hook mechanism

REF.NO	CODE	Q'TY	品名	NAME OF PARTS	RM
1	SA4435101	1	カマドダイ845イトキリLクミ	ROTARY HOOK BASE,845TR(L)	
2	SA3961001	1	パイプ	PIPE	
3	SA4029001	1	カマジクメタルU	ROTARY HOOK SHAFT BUSH	
4	S09260001	1	スラストリングA< t=1.2 >	THRUST RING, A :1.2MM< t=1.2 >	
4	SA4038001	1	スラストリング< t=1.0 >	THRUST RING< t=1.0 >	
4	S09261001	1	スラストリングB< t=1.4 >	THRUST RING, B :1.4MM< t=1.4 >	
4	SA4444001	1	スラストリング0.8< t=0.8 >	THRUST RING, 0.8MM< t=0.8 >	
5	S07420000	1	ニードルベアリング	NEEDLE BEARING	
6	S07419001	1	ストツブリング	RETAINING RING	
7	SA2557001	1	カマジクメタルD	ROTARY HOOK SHAFT BUSH	
8	SA3856001	1	オープナーリンク	OPENER LINK	
9	SA3859001	1	オープナーレバー	OPENER LEVER	
10	SA2560001	1	オープナーリンクジク	SHAFT, O-LINK	
11	025710132	1	ヒラザガネシヨウ4.76	WASHER PLAIN S SM4.76	
12	021500316	1	3シュナツト5	NUT, 3 M5	
13	SA3889101	1	オープナーレバージク	O-LEVER SHAFT	
14	SA4026001	1	クミヒモ4X4 L=100	WICK, 4X4 L=100	
15	012500536	1	アナヒラ5X5	SET SCREW, SOCKET (FT) M5X5	
16	S38212001	1	オープナー	OPENER	
17	154965001	1	アナボルト3.57X8	BOLT, SOCKET SM3.57X8	
18	SA2562101	1	カマドダイカバーL	ROTARY HOOK BASE COVER, L	
19	062300612	4	ナベコ3X6	SCREW, PAN M3X6	
20	SA2572001	1	スパイラルギヤ ネジツキ	SPIRAL GEAR SCREW ASSY	
21	SA2574001	2	トメネジM6ホソメ	SET SCREW, (FT) M6	
22	SA2575001	1	トメネジM6ホソメ	SET SCREW, (FT) M6	
23	SA6301001	1	ピニオン ネジツキ	PINION GEAR SCREW ASSY	
24	SA2574001	3	トメネジM6ホソメ	SET SCREW, (FT) M6	
25	SA3054001	1	スラストザガネL	THRUST WASHER, L	
26	SA4042001	1	フェルトULクミ	FELT UL ASSY	
27	062400616	1	ナベコ4X6	SCREW, PAN M4X6	
28	SA4044001	1	フェルトDLクミ	FELT DL ASSY	
29	062400616	1	ナベコ4X6	SCREW, PAN M4X6	
30	SA4012001	1	フェルト	FELT	
31	SA3894001	1	フェルトオサエ	FELT SUPPORT	
32	062400616	1	ナベコ4X6	SCREW, PAN M4X6	
33	SA2717001	2	ストツパネジ	STOPPER SCREW	
34	SA2676001	1	イドウハウケ	MOVABLE KNIFE BRACKET	
35	062400812	2	ナベコ4X8	SCREW PAN M4X8	
36	S07525000	1	シタイトホジバネ	SPRING, PLATE	
37	141544001	2	シメネジ3.18	SCREW, SM3.18-40X3	
38	SA3912001	1	イドウハレバー	MOVABLE KNIFE LEVER	
39	SA2675001	1	セットカラー	SET SCREW COLLAR	
40	S23651001	1	アナヒラ6X6ホソメ	SET SCREW, SOCKET (FT) M6X6	
41	SA2671001	1	イトキリレバーL	THREAD TRIMMER LEVER, L	
42	062501212	1	ナベコ5X12	SCREW, PAN M5X12	
64	SA6294001	1	スラストリング	THRUST RING	
65	SA6307001	1	ピニオンセット	PINION GEAR SET	
44	SA4436101	1	カマドダイ845イトキリRクミ	ROTARY HOOK BASE,845TR(R)	
2	SA3961001	1	パイプ	PIPE	
3	SA4029001	1	カマジクメタルU	ROTARY HOOK SHAFT BUSH	
4	S09260001	1	スラストリングA< t=1.2 >	THRUST RING, A :1.2MM< t=1.2 >	
4	SA4038001	1	スラストリング< t=1.0 >	THRUST RING< t=1.0 >	
4	S09261001	1	スラストリングB< t=1.4 >	THRUST RING, B :1.4MM< t=1.4 >	
4	SA4444001	1	スラストリング0.8< t=0.8 >	THRUST RING, 0.8MM< t=0.8 >	
5	S07420000	1	ニードルベアリング	NEEDLE BEARING	
6	S07419001	1	ストツブリング	RETAINING RING	
7	SA2557001	1	カマジクメタルD	ROTARY HOOK SHAFT BUSH	
8	SA3856001	1	オープナーリンク	OPENER LINK	
9	SA3859001	1	オープナーレバー	OPENER LEVER	
10	SA2560001	1	オープナーリンクジク	SHAFT, O-LINK	
11	025710132	1	ヒラザガネシヨウ4.76	WASHER PLAIN S SM4.76	
12	021500316	1	3シュナツト5	NUT, 3 M5	

K1 . かま関係 / Rotary hook mechanism

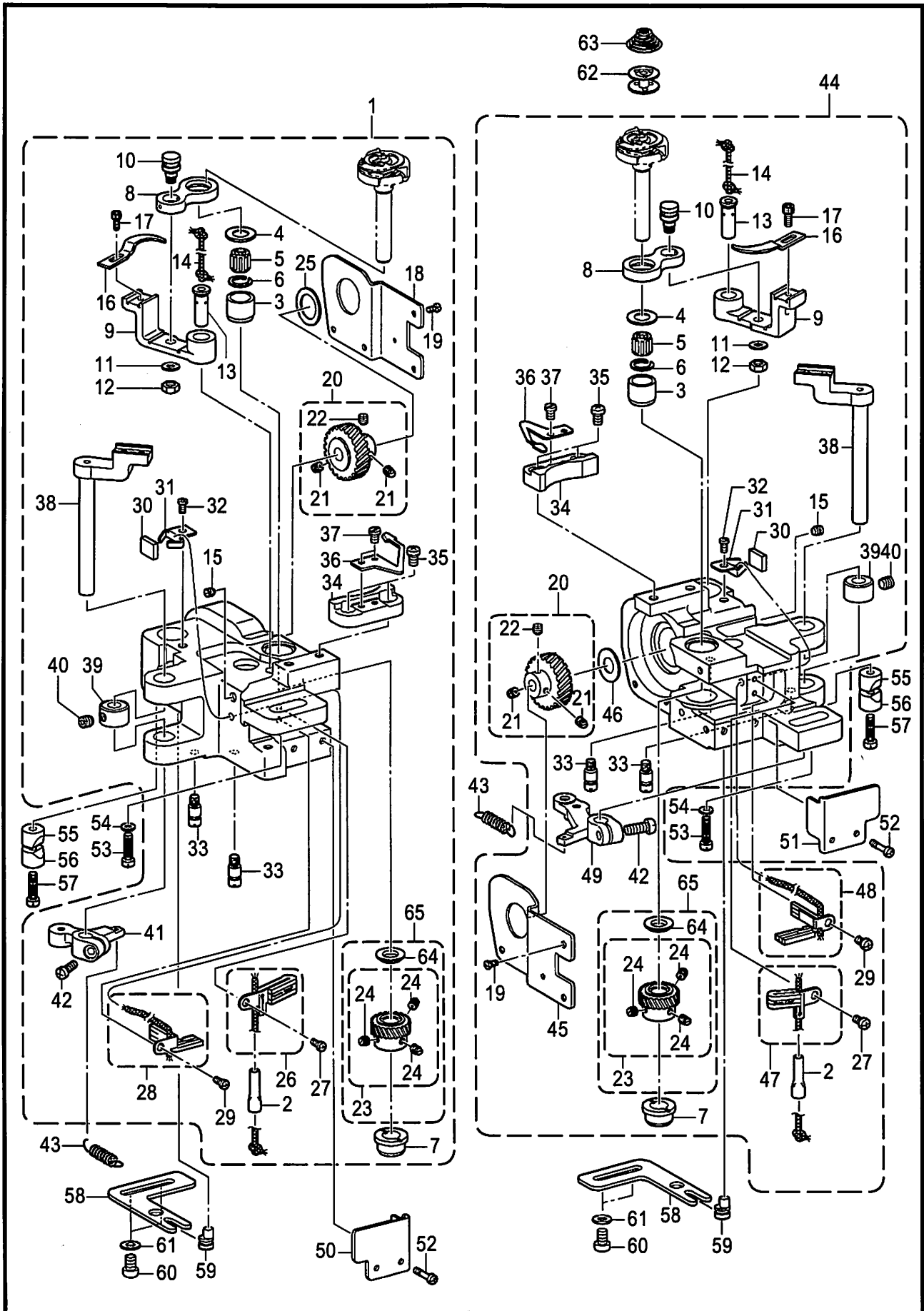

from the library of Diamond Needle Corp

K1 . かま関係 / Rotary hook mechanism

REF.NO	CODE	Q'TY	品名	NAME OF PARTS	RM
13	SA3889101	1	オープナーレバージク	O-LEVER SHAFT	
14	SA4026001	1	クミヒモ4X4 L=100	WICK, 4X4 L=100	
15	012500536	1	アナヒラ5X5	SET SCREW, SOCKET (FT) M5X5	
16	S38212001	1	オープナー	OPENER	
17	154965001	1	アナボルト3.57X8	BOLT, SOCKET SM3.57X8	
45	SA2563101	1	カマダイカバー-R	ROTARY HOOK BASE COVER, R	
19	062300612	4	ナベコ3X6	SCREW, PAN M3X6	
20	SA4549001	1	スパイラルギヤ ネジツキ	SPIRAL GEAR SCREW ASSY	
21	SA2574001	2	トメネジM6ホソメ	SET SCREW, (FT) M6	
22	SA2575001	1	トメネジM6ホソメ	SET SCREW, (FT) M6	
23	SA6301001	1	ピニオン ネジツキ	PINION GEAR SCREW ASSY	
24	SA2574001	3	トメネジM6ホソメ	SET SCREW, (FT) M6	
46	SA2579001	1	スラストザガネ	SPECER	
47	SA4043001	1	フェルトURクミ	FELT UR ASSY	
27	062400616	1	ナベコ4X6	SCREW, PAN M4X6	
48	SA4045001	1	フェルトDRクミ	FELT DR ASSY	
29	062400616	1	ナベコ4X6	SCREW, PAN M4X6	
30	SA4012001	1	フェルト	FELT	
31	SA3894001	1	フェルトオサエ	FELT SUPPORT	
32	062400616	1	ナベコ4X6	SCREW, PAN M4X6	
33	SA2717001	2	ストツバネジ	STOPPER SCREW	
34	SA2676001	1	イドウハウケ	MOVABLE KNIFE BRACKET	
35	062400812	2	ナベコ4X8	SCREW PAN M4X8	
36	S07525000	1	シタイトホジバネ	SPRING, PLATE	
37	141544001	2	シメネジ3.18	SCREW, SM3.18-40X3	
38	SA3912001	1	イドウハレバー	MOVABLE KNIFE LEVER	
39	SA2675001	1	セットカラー	SET SCREW COLLAR	
40	S23651001	1	アナヒラ6X6ホソメ	SET SCREW, SOCKET (FT) M6X6	
49	SA2670001	1	イトキリレバー-R	THREAD TRIMMER LEVER, R	
42	062501212	1	ナベコ5X12	SCREW, PAN M5X12	
64	SA6294001	1	スラストリング	THRUST RING	
65	SA6307001	1	ピニオンセット	PINION GEAR SET	
			<-□□5用>	<For"-□□5">	
43	SA2826001	2	イトキリレバーバネ	SPRING, EXTENSION	
			<-□□3用>	<For"-□□3">	
43	SA4458001	2	イトキリレバーバネB	SPRING, EXTENSION, B	
50	SA3988001	1	カマダイカバー-FL	ROTARY HOOK BASE COVER, FL	
51	SA3916001	1	カマダイカバー-FR	ROTARY HOOK BASE COVER, FR	
52	SA2825001	4	シメネジM3X12	SCREW, M3X12	
53	SA2556001	2	シメネジM6X25	SCREW, M6X25	
54	115947001	2	ザガネ	WASHER, PLAIN 6.35	
55	SA2722001	2	ピンチスリーブA	PINCH SLEEVE A	
56	SA2565001	2	ピンチスリーブB	PINCH SLEEVE B	
57	SA2556001	2	シメネジM6X25	SCREW, M6X25	
58	SA2567001	2	ハリスキチヨウセツイタ	NEEDLE UPPER POSITIONING PLATE	
59	SA2568001	2	ハリスキチヨウセツジク	NEEDLE UPPER POSITIONING SHAFT	
60	062061016	4	ナベコ6X10	SCREW, PAN M6X10	
61	025060136	4	ヒラザガネシヨウ6	WASHER, PLAIN S 6	
62	S01928151	2	ボビン	BOBBIN	
63	148602001	2	クウテンボウシバネ	ANTI-SPIN SPRING	

K2 . かま関係 / Rotary hook mechanism

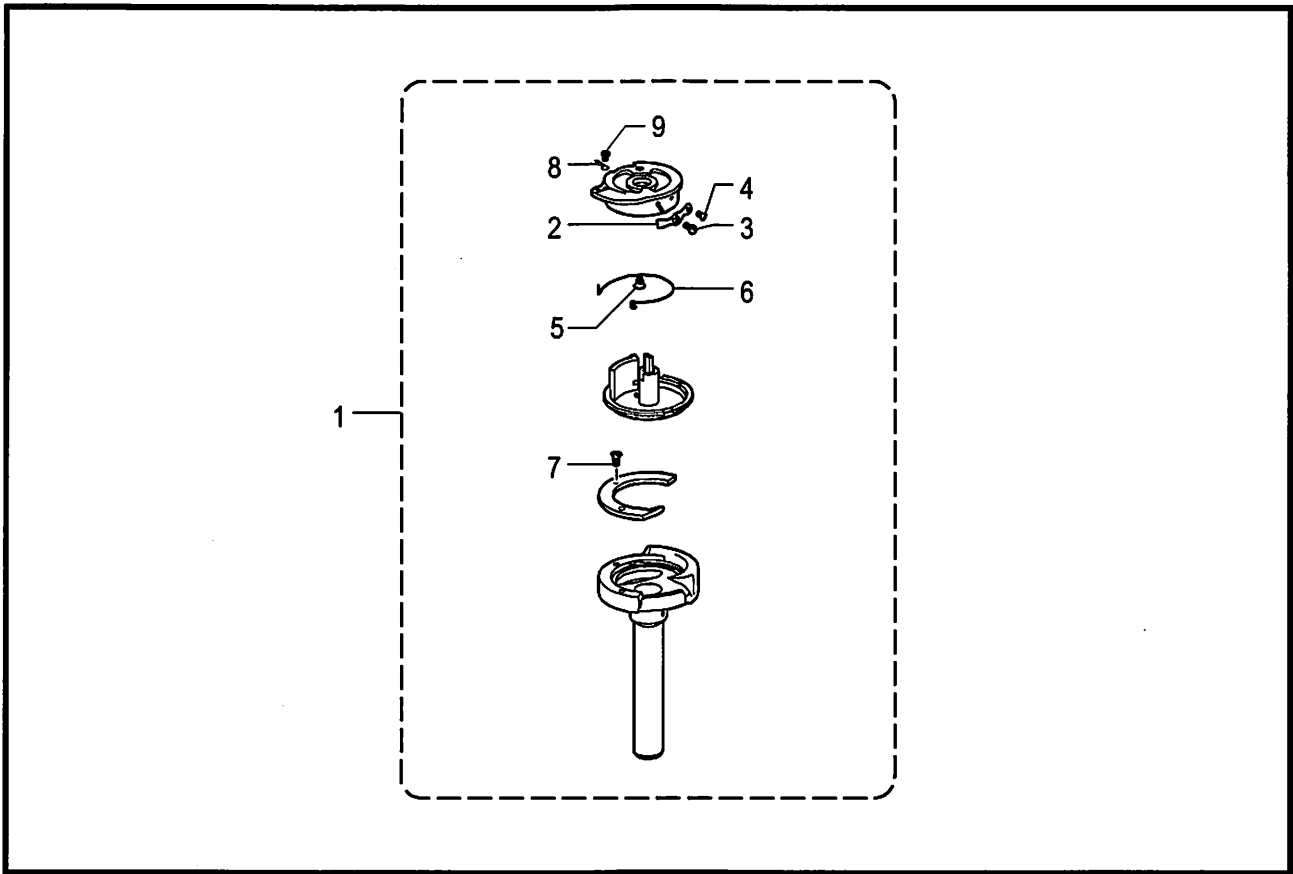

T-8452A-301

L . ゲージ関係 / Gauge parts

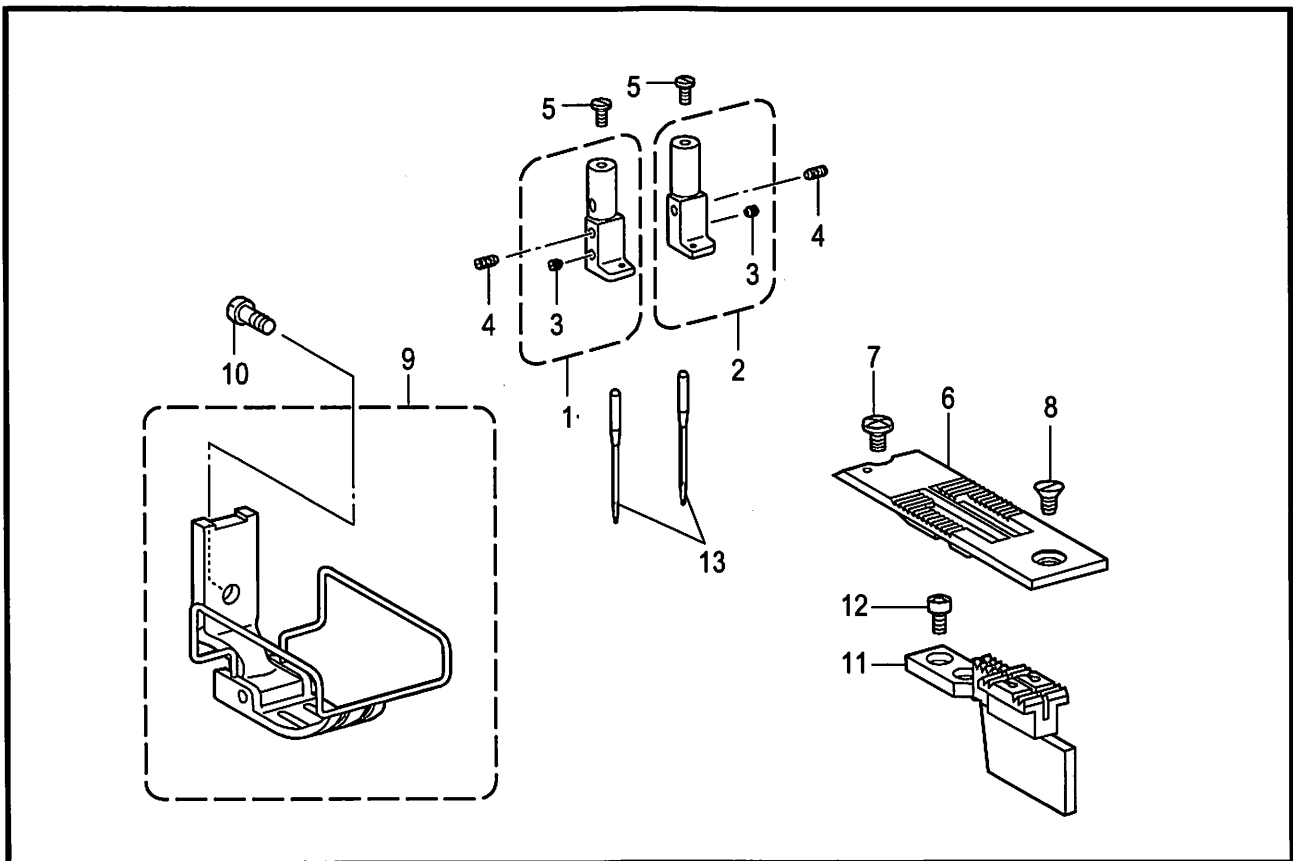

T-8452A-231

K2 . かま関係 / Rotary hook mechanism

REF.NO	CODE	Q'TY	品名	NAME OF PARTS	RM
1	*	1	カマハコクミ	ROTARY HOOK BOX ASSY	
2	151025001	1	チヨウシバネ	TENSION SPRING	
3	S01567001	1	チヨウシネジ	TENSION ADJUSTING SCREW	
4	S01568001	1	チヨウシバネトメネジ	SET SCREW	
5	151035001	1	タルミトリバネトメネジ	SET SCREW	
6	151034001	1	シタイトタルミトリバネ	TENSION SPRING	
7	151027001	2	ウチカマオサエトメネジ	SET SCREW	
8	159801001	1	イトオサエワイヤー	THREAD PRESSER WIRE	
9	159802001	1	シメネジ1.59X2	SCREW, SM1.59X2	
<p>* については、仕様別部品一覧表(P.52)でお調べください。 As for symbol * look it up in the different parts list on page 52.</p>					

T-8452A-301

L . ゲージ関係 / Gauge parts

REF.NO	CODE	Q'TY	品名	NAME OF PARTS	RM
1	*	1	ハリダキLクミ	NEEDLE CLAMP ASSY,L	
2	*	1	ハリダキRクミ	NEEDLE CLAMP ASSY,R	
3	013660412	2	トメクボミ3.18-40X4	SET SCREW (CP) SM3.18-40X4	
4	S13085001	2	トメネジ3.18	SET SCREW, SM3.18	
5	149831101	2	アタマツキトメネジ3.18	SET SCREW, SM3.18	
6	*	1	ハリイタ	NEEDLE PLATE	
7	S11244001	1	シメネジ4.37	SCREW, SM4.37	
8	100032004	1	サラネジ4.37	SCREW, FLAT SM4.37-40X8	
9	*	1	オサエクミ	PRESSER FOOT ASSY	
10	113050001	1	シメネジ3.57	SCREW, SM3.57	
11	*	1	オクリバ	FEED DOG	
12	S07494001	2	シメネジ3.18	SCREW, W/SOCKET SM3.18X7	
13	*	2	ミシンハリDPX5	NEEDLE, DPX5	
<p>* については、ゲージ部品一覧表(P.53-56)でお調べください。 As for symbol * look it up in the gauge parts list on page 53-56.</p>					

T-8452A-231

M. 下軸関係 / Lower shaft mechanism

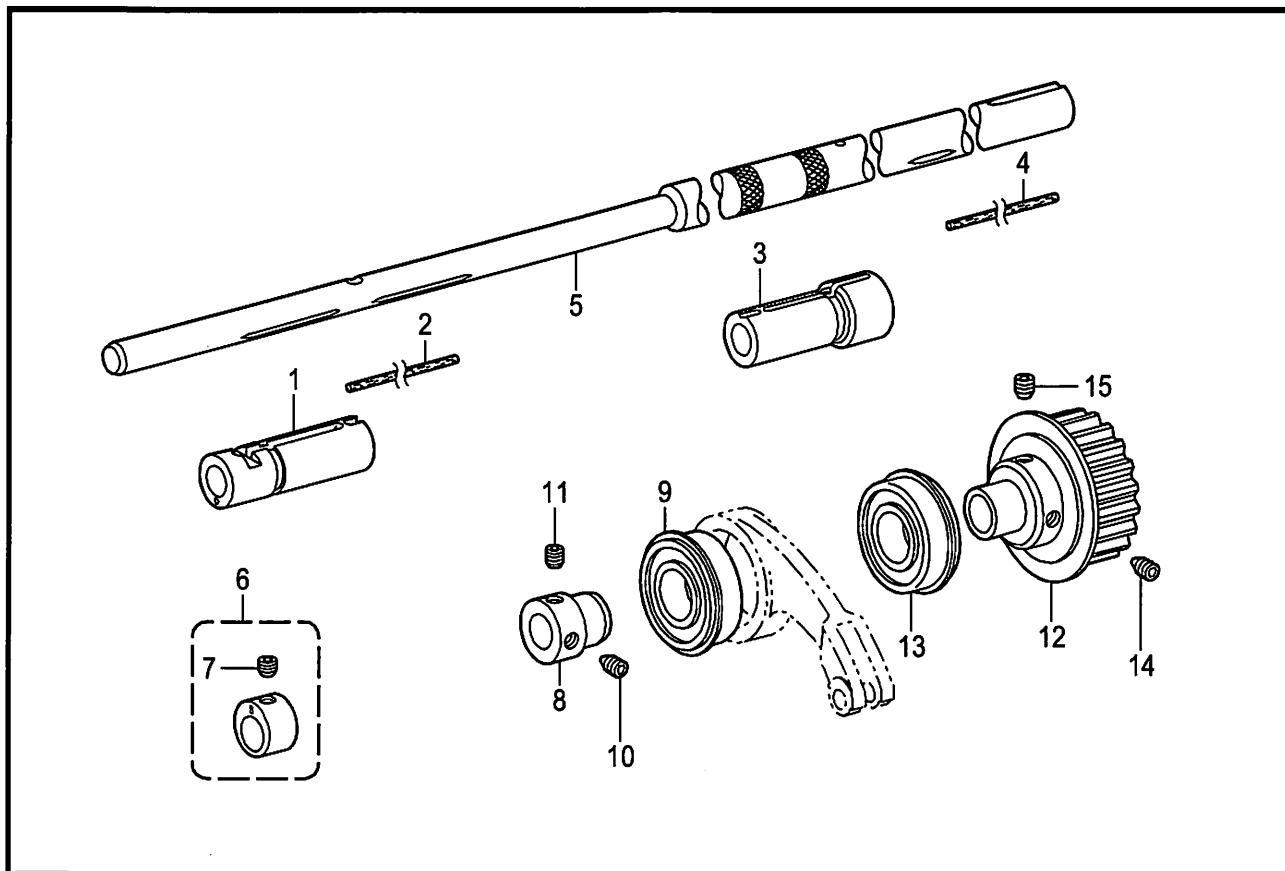

T-8452A-305

N. 糸緩め関係 / Tension release mechanism

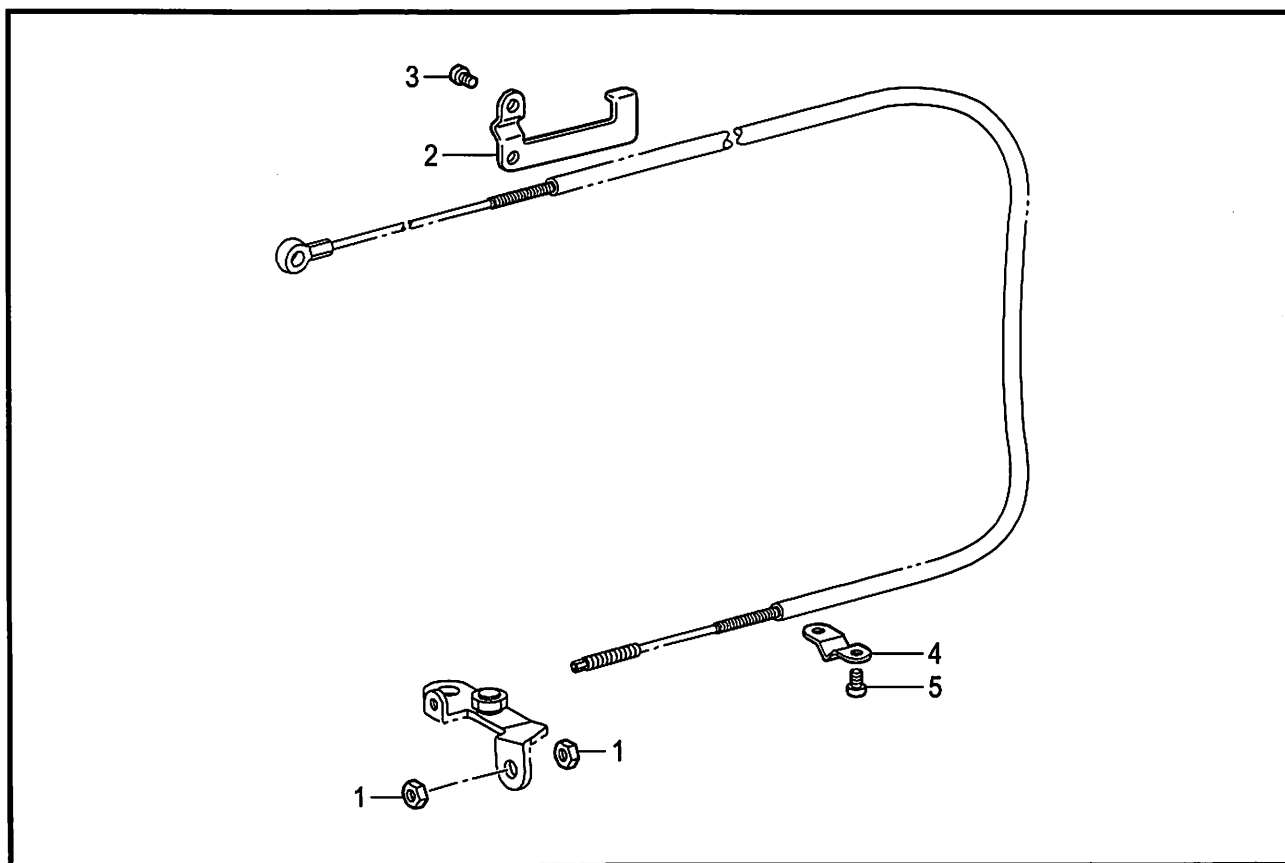

T-8452A-404

M . 下軸関係 / Lower shaft mechanism

REF.NO	CODE	Q'TY	品名	NAME OF PARTS	RM
1	SA3890001	1	カマドダイメタルL	ROTARY HOOK BASE BUSH, L	
2	SA4585001	1	フェルト	FELT	
3	SA3891001	1	カマドダイメタルR	ROTARY HOOK BASE BUSH, R	
4	SA4585001	1	フェルト	FELT	
5	SA2571001	1	シタジク	LOWER SHAFT	
6	SA2580101	1	ジヨウゲヘンシンリンTRクミ	F-LIFTING ECCENTRIC WHEEL ASSY	
7	SA4509001	1	トメネジM6ホソメ	SET SCREW (FT) M6	
8	SA2584001	1	タマジクウケブツシュ	BALL BEARING BUSH	
9	072600480	1	Tタマジクウケ6004ZZ	BALL BEARING, THRUST 6004ZZ	
10	SA2585001	1	アナトガリ6X10ホソメ	SET SCREW, SOCKET (FT) M6	
11	S25236001	1	アナヒラ6X10ホソメ	SET SCREW, SOCKET (FT) M6X10	
12	SA2587101	1	タイミングプーリDクミ	TIMING PULLEY ASSY, D	
13	158115001	1	タマジクウケ6204ZZNR	BALL BEARING, 6204ZZNR	
14	SA2585001	1	アナトガリ6X10ホソメ	SET SCREW, SOCKET (FT) M6	
15	SA4213001	1	アナトメネジ6X10ホソメ	SET SCREW, SOCKET (CP) M6X10	

T-8452A-305

N . 糸緩め関係 / Tension release mechanism

REF.NO	CODE	Q'TY	品名	NAME OF PARTS	RM
1	110161004	2	ナット4.76	NUT, SM4.76	
2	SA2678001	1	イトユルメワイヤ-オサエ	TENSION RELEASE WIRE HOLDER	
3	062500816	2	ナベコ5X8	SCREW, PAN M5X8	
4	SA2679001	1	イトユルメワイヤ-オサエ	TENSION RELEASE WIRE HOLDER	
5	062060816	2	ナベコ6X8	SCREW, PAN M6X8	

T-8452A-404

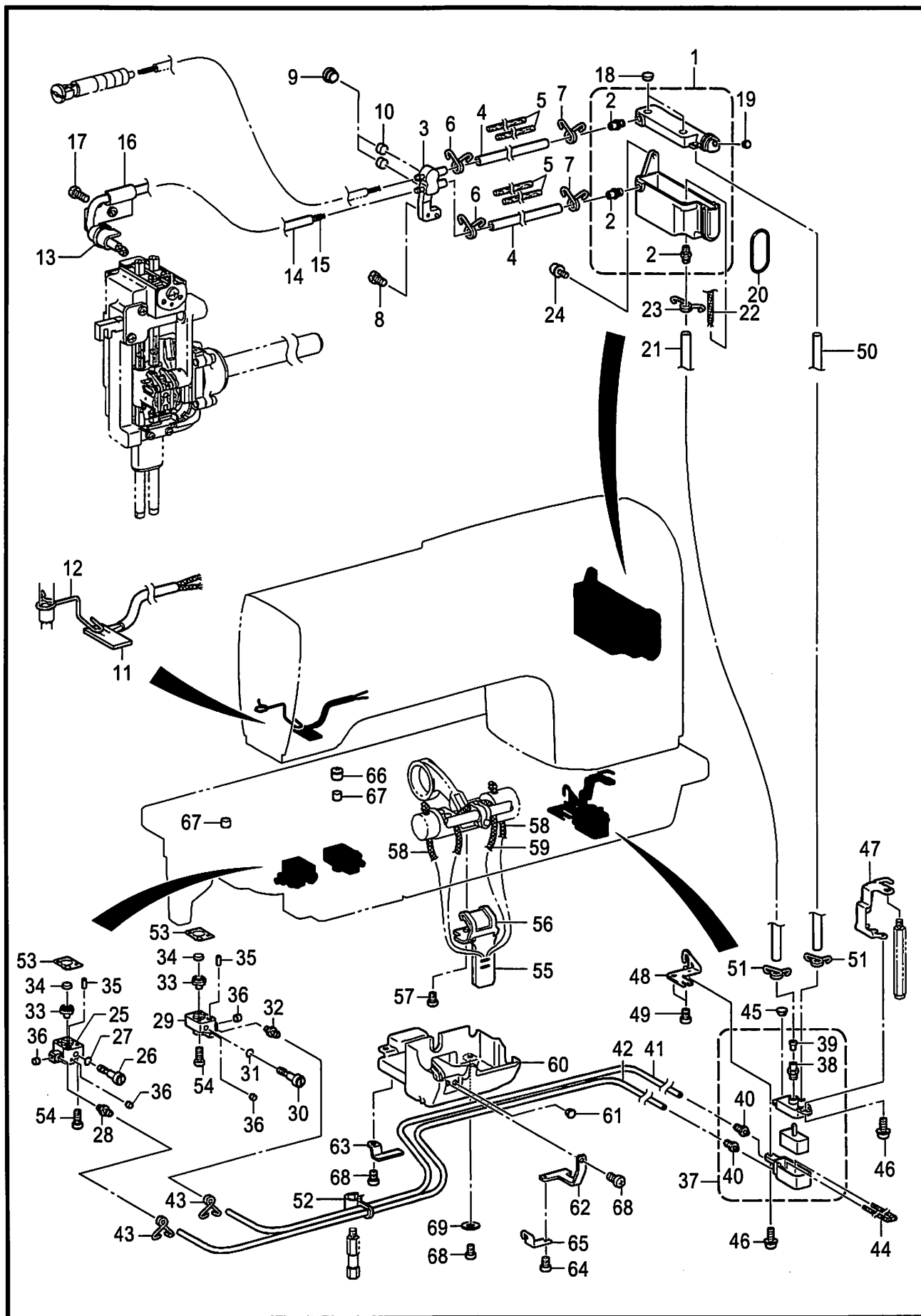

from the library of Diamond Needle Corp

P. 給油潤滑関係 / Lubrication

REF.NO	CODE	Q'TY	品名	NAME OF PARTS	RM
1	SA2814201	1	オイルタンククミ	OIL TANK ASSY	
2	SA3040001	3	オイルクチ	OIL FEEDING PIPE	
3	SA3946001	1	キユウユタ-ミナル	OIL TERMINAL	
4	SA2956001	2	ビニルチューブ	OIL TUBE, L=135	
5	SA2957001	4	フェルト	FELT	
6	SA3055101	2	チューブストツパー	TUBE CLIP	
7	SA3055101	2	チューブストツパー	TUBE CLIP	
8	062500816	1	ナベコ5X8	SCREW PAN M5X8	
9	SA2929001	2	ゴムセン12.5	RUBBER CAP, 12.5	
10	S38266000	2	カマジクフェルト	ROTARY HOOK SHAFT FELT	
11	SA5224001	1	フェルトクミ	FELT ASSY	
12	SA4033101	1	フェルトオサエ	FELT SUPPORT	
13	228475000	1	ケツソクバンド1.9X80	FASTENING BAND, 1.9X80	
14	S49623000	1	ビニルチューブ	OIL TUBE, L=280	
15	SA5293001	1	クミヒモ4X4	WICK L=410	
16	SA5154201	1	キユウユササエ	OIL SUPPORT	
17	062501016	1	ナベコ5X10	SCREW PAN M5X10	
18	SA2929001	2	ゴムセン12.5	RUBBER CAP, 12.5	
19	104450101	1	ゴムセン8	RUBBER CAP, 8	
20	081038070	1	リングP38	O RING P38	
21	SA2723001	1	ビニルチューブ	OIL TUBE, L=210	
22	SA2724001	1	クミヒモ	WICK, L=400	
23	SA3055101	1	チューブストツパー	TUBE CLIP	
24	0A5501006	2	+ナベザクミ5X10DB	SCREW PAN (S/P WASHER) M5X10	
25	SA3896001	1	キユウユブロックL	OIL BLOCK,L	
26	SA2599001	1	オイルチヨウセツネジ	OIL ADJUSTING SCREW	
27	081004070	1	リングP4	O RING P4	
28	SA3147001	1	オイルクチ2.5	OIL FEEDING PIPE 2.5	
29	SA3898001	1	キユウユブロックR	OIL BLOCK,R	
30	SA2599001	1	オイルチヨウセツネジ	OIL ADJUSTING SCREW	
31	081004070	1	リングP4	O RING P4	
32	SA3147001	1	オイルクチ2.5	OIL FEEDING PIPE 2.5	
33	SA3061001	2	ゴムパツキン	RUBBER PACKING	
34	SA2727101	2	カマジクフェルト	ROTARY HOOK SHAFT FELT	
35	S05246000	2	フェルト	FELT	
36	142274101	4	ゴムセン4.2	RUBBER CAP, 4.2	
37	SA3037001	1	サブタンククミ	SUB-TANK ASSY	
38	SA3040001	1	オイルクチ	OIL FEEDING PIPE	
39	SA3060001	1	バルブパツキン	VALVE PACKING	
40	SA3147001	2	オイルクチ2.5	OIL FEEDING PIPE 2.5	
41	SA2596001	1	ビニルチューブ	OIL TUBE, L=400	
42	SA2597001	1	ビニルチューブ	OIL TUBE, L=500	
43	S07876101	2	チューブストツパー	TUBE CLIP	
44	SA2598101	1	クミヒモ	WICK, L=1250	
45	104450101	1	ゴムセン8	RUBBER CAP, 8	
46	0A4400806	2	+ナベザクミ4X8DA	SCREW PAN (S/P WASHER) M4X8	
47	SA3045201	1	サブタンクトリツケイタA	SUB-TANK SETTING PLATE, A	
48	SA3046001	1	サブタンクトリツケイタB	SUB-TANK SETTING PLATE, B	
49	062060816	2	ナベコ6X8	SCREW PAN M6X8	
50	SA3044001	1	ビニルチューブ	OIL TUBE, L=242	
51	SA3055101	2	チューブストツパー	TUBE CLIP	
52	SA3047001	1	チューブササエ	TUBE SUPPORT	
53	SA3923001	2	カマドダイDパツキン	ROTARY HOOK BASE D PACKING	
54	062401616	4	ナベコ4X16	SCREW PAN M4X16	
55	SA2604001	1	キリカエキフェルト	FEED REGULATOR FELT	
56	SA2605001	1	フェルトオサエイタ	FELT SUPPORT	
57	062500616	1	ナベコ5X6	SCREW PAN M5X6	
58	108802001	2	クミヒモ4X4	WICK, 4X4 L=250	
59	108801001	1	クミヒモ4X4	WICK, 4X4 L=350	
60	SA2606101	1	オイルカバー	OIL COVER	
61	104450101	1	ゴムセン8	RUBBER CAP, 8	
62	SA3048101	1	チューブオサエA	TUBE SUPPORT, A	
63	SA3049001	1	チューブオサエB	TUBE SUPPORT, B	

T-8452A-350

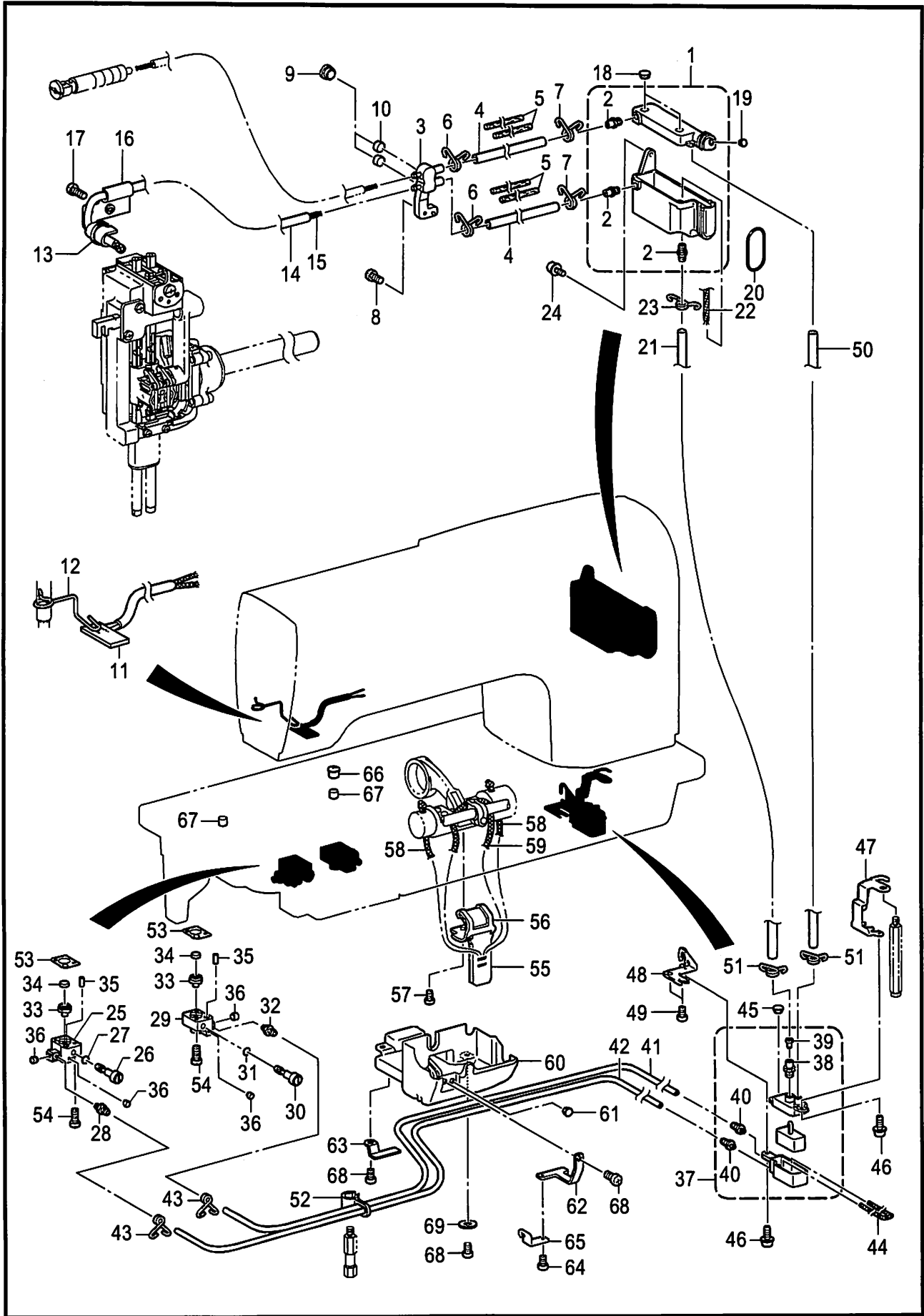

from the library of Diamond Needle Corp

P. 給油潤滑関係 / Lubrication

REF.NO	CODE	Q'TY	品名	NAME OF PARTS	RM
64	062400616	1	ナベコ4X6	SCREW PAN M4X6	
65	SA4014001	1	チューブガイド	TUBE GUIDE	
66	140890009	1	オイルカップ	OIL CAP	
67	112753001	2	フェルト	FELT	
68	062061016	3	ナベコ6X10	SCREW PAN M6X10	
69	025060236	1	ヒラザガネチューブ	WASHER PLAIN M 6	

T-8452A-350

from the library of Diamond Needle Corp

Q.糸通し関係 / Threading mechanism

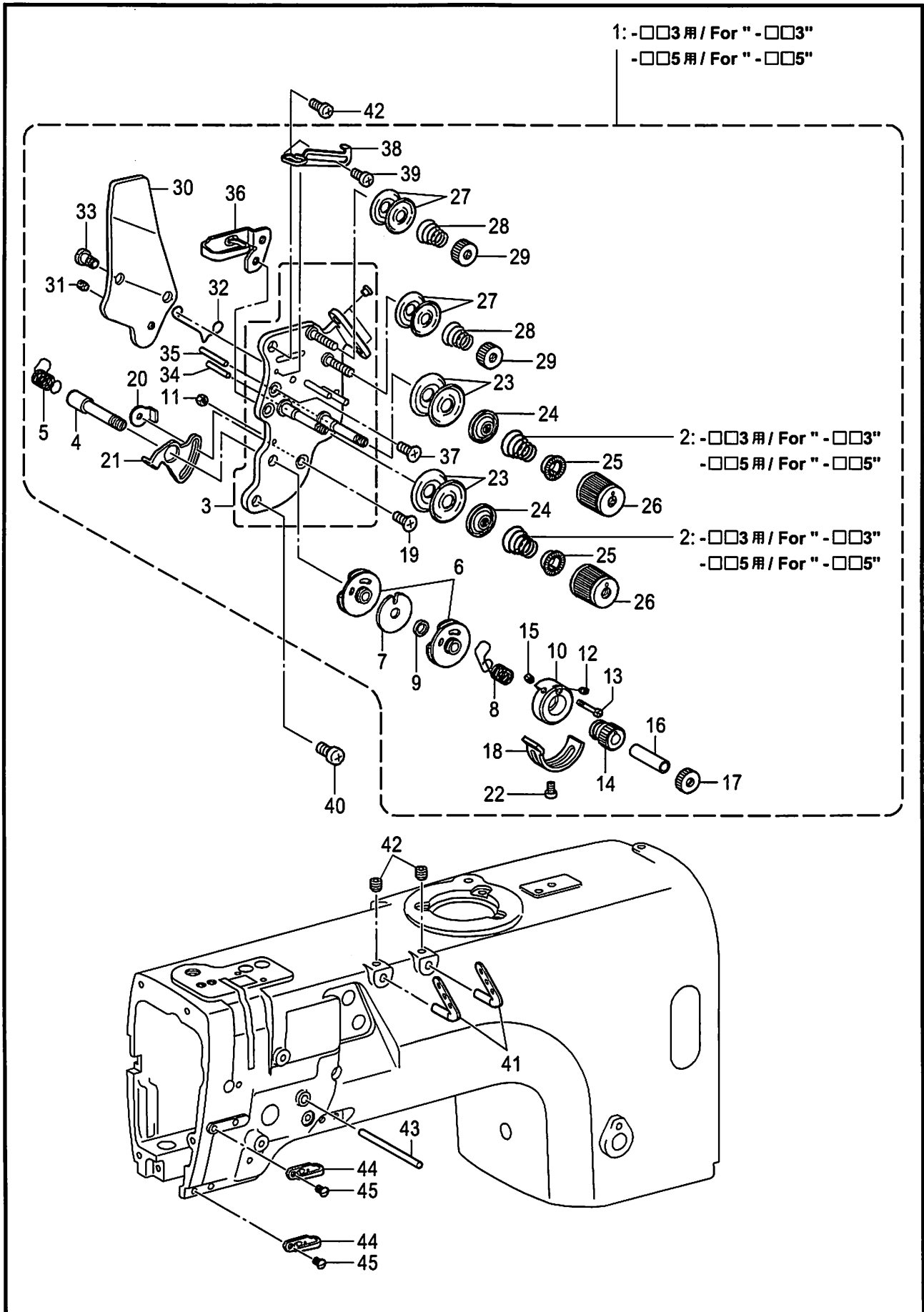

Q . 系通し関係 / Threading mechanism

REF.NO	CODE	QTY	品名	NAME OF PARTS	RM
1	SA3417001	1	<-□□3用> ウワイトチヨウシクミ-3	<For"-□□3"> UPPER THREAD TENSION ASSY, -3	
2	SA3415001	2	イトチヨウシバネL	TENSION SPRING, L	
1	SA2607001	1	<-□□5用> ウワイトチヨウシクミ-5	<For"-□□5"> UPPER THREAD TENSION ASSY, -5	
2	SA3416001	2	イトチヨウシバネLL	TENSION SPRING, LL	
3	SA4212001	1	イトチヨウシダイクミ	TENSION PLATE ASSY	
4	SA2613001	1	チヨウシジク	TENSION STUD	
5	SA2614001	1	イトトリバネL	THREAD TAKE-UP SPRING, L	
6	SA2615001	2	イトトリバネアンナイクミ	GUIDE ASSY, T/TAKE-UP SPRING	
7	SA2619001	1	スペーサ-	SPACER	
8	SA2623001	1	イトトリバネR	THREAD TAKE-UP SPRING, R	
9	SA2620001	1	カラ-	COLLAR	
10	SA2621001	1	ストツパウケ	STOPPER SUPPORT	
11	021300106	1	1シユナツト3	NUT, 1 M3	
12	SA2626001	1	トメネジ3.5	SET SCREW, (CP) M3.5	
13	SA2624001	1	バネアンナイトメネジ	SPRING GUIDE SET SCREW	
14	SA2625001	1	チヨウセツツマミ	ADJUSTING THUMB	
15	SA2626001	1	トメネジ3.5	SET SCREW, (CP) M3.5	
16	SA2627001	1	カラ-	COLLAR	
17	SA2628001	1	イトチヨウシナツト	TENSION NUT	
18	SA2629001	1	イトトリバネストツパ	STOPPER	
19	061350616	1	サラコ35X6	SCREW, FLAT M3.5X6	
20	SA2824001	1	マワリドメナツトM3.5	NUT, WHIRL-STOP M3.5	
21	SA2630001	1	イトトリバネストツパ	STOPPER	
22	062350512	1	ナベコ35X5	SCREW, PAN M3.5X5	
23	145446001	4	イトチヨウシサラ	DISC, TENSION	
24	159805001	2	イトチヨウシサラオサエ	TENSION DISC PRESSER	
25	S20681000	2	チヨウシバネウエザガネ	WASHER	
26	S20682105	2	イトチヨウシナツト	TENSION NUT	
27	144504001	4	イトアンナイサラ	THREAD GUIDE DISC	
28	154560001	2	プレテンションバネA	PRE-TENSION SPRING, A	
29	155510001	2	イトチヨウシナツト	TENSION NUT	
30	SA2632001	1	イトユルメイタ	TENSION RELEASE PLATE	
31	012500536	1	アナヒラ5X5	SET SCREW, SOCKET (FT) M5X5	
32	S38274001	1	イトユルメバネ	T-RELEASE SPRING	
33	SA2633001	2	ダンネジ3.5	SHOULDER SCREW, M3.5	
34	SA4506001	1	イトユルメピンL	TENSION RELEASE PIN, L	
35	SA4507001	1	イトユルメピンR	TENSION RELEASE PIN, R	
36	SA2634001	1	ア-ムイトアンナイU	THREAD GUIDE, U :ARM	
37	061350616	2	サラコ35X6	SCREW, FLAT M3.5X6	
38	SA2635001	1	イトリヨウチヨウセイ	THREAD QUANTITY ADJUST	
39	062300616	1	ナベコ3X6	SCREW, PAN M3X6	
40	062500816	2	ナベコ5X8	SCREW, PAN M5X8	
41	SA2636001	2	ミツメイトカケ	THREAD RETAINER	
42	012060636	2	アナヒラ6X6	SET SCREW, SOCKET (FT) M6X6	
43	SA2637001	1	イトユルメジク	BAR, TENSION RELEASE	
44	SA2638001	2	ア-ムイトアンナイM	THREAD GUIDE, M :ARM	
45	SA2640001	2	サラネジ5X8	SCREW, FLAT M5X8	

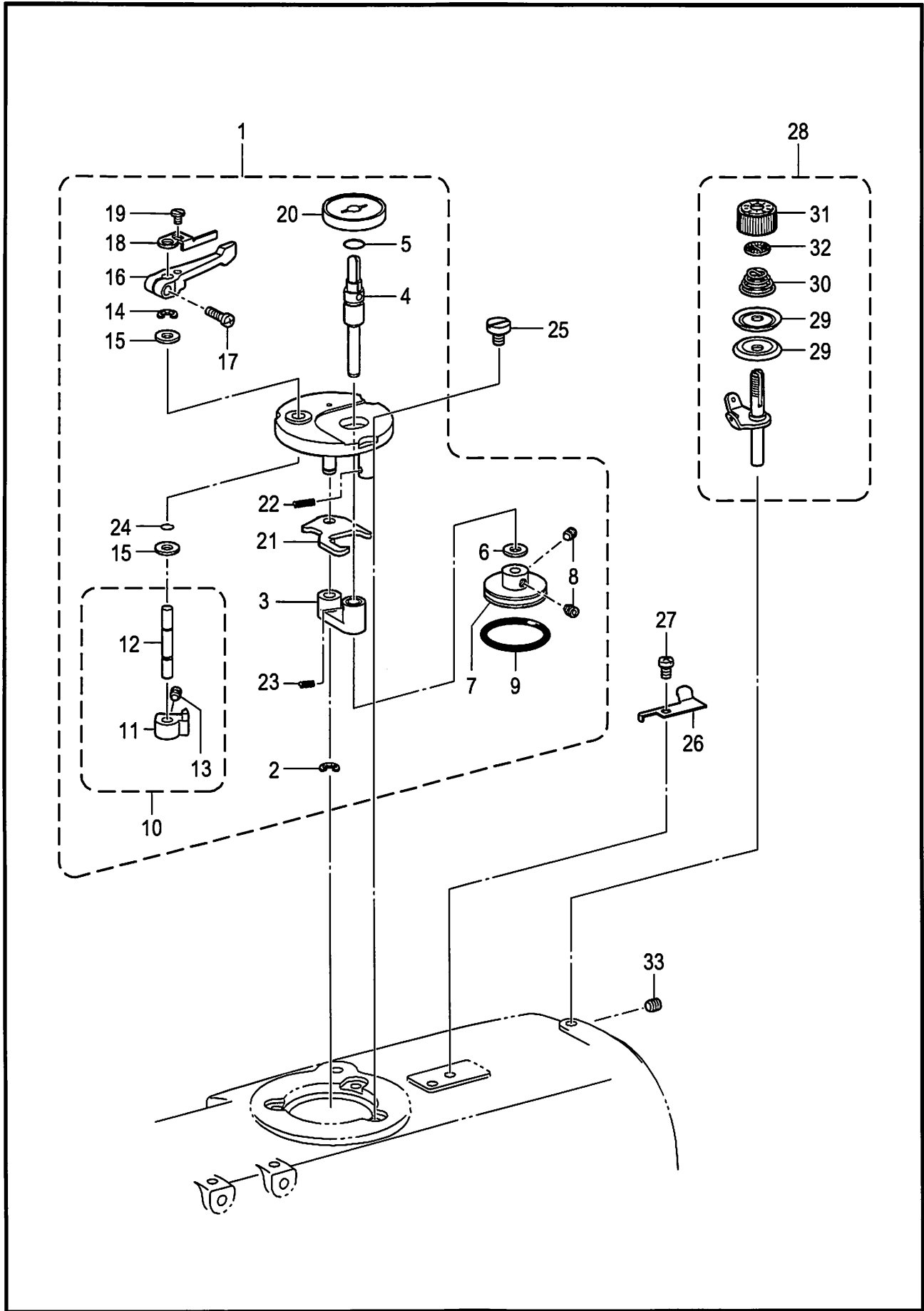

R . 糸巻関係 / Bobbin winder mechanism

REF.NO	CODE	QTY	品名	NAME OF PARTS	RM
1	SA1971101	1	イトマキユニット	BOBBIN WINDER UNIT	
2	048040342	1	トメワE4	RETAINING RING, E4	
3	SA1975001	1	イトマキジクウケクミ	B-WINDER SHAFT SUPPORT ASSY	
4	SA1978001	1	イトマキジク	BOBBIN WINDER SHAFT	
5	081009070	1	OリングP9	O RING, P9	
6	025060136	1	ヒラザガネシヨウ6	WASHER, PLAIN S 6	
7	SA1980001	1	イトマキクルマ	BOBBIN WINDER WHEEL	
8	012500536	2	アナヒラ5X5	SET SCREW, SOCKET (FT) M5X5	
9	S25789000	1	ゴムワ29	RUBBER RING, 29	
10	SA1981101	1	ボビンオサエカムクミ	BOBBIN PRESSER CAM ASSY	
11	SA1982101	1	ボビンオサエカム	BOBBIN PRESSER CAM	
12	SA1983001	1	イトマキウデジク	BOBBIN WINDER ARM SHAFT	
13	012500536	1	アナヒラ5X5	SET SCREW, SOCKET (FT) M5X5	
14	048040342	1	トメワE4	RETAINING RING, E4	
15	025060136	2	ヒラザガネシヨウ6	WASHER, PLAIN S 6	
16	SA1984001	1	ボビンオサエウデ	BOBBIN PRESSER ARM	
17	062401216	1	ナベコ4X12	SCREW, PAN M4X12	
18	SA1985001	1	ボビンオサエ	BOBBIN PRESSER	
19	S23418002	1	シメネジ4X5	SCREW, M4X5	
20	SA1988001	1	ボビンウケ	BOBBIN SUPPORT	
21	SA1989001	1	イトマキレバー	BOBBIN WINDER LEVER	
22	SA1990101	1	モドシバネ	SPRING	
23	SA1991001	1	イトマキダイバネ	BOBBIN WINDER BASE SPRING	
24	SA2190001	1	OリングSS5	O RING, SS5	
25	SA1992101	3	イトマキコテイネジ	BOBBIN WINDER FIXED SCREW	
26	SA1360001	1	メス	KNIFE	
27	062500616	1	ナベコ5X6	SCREW, PAN M5X6	
28	SA1994001	1	イトマキチヨウシクミ	BOBBIN WINDER TENSION ASSY	
29	145446001	2	イトチヨウシサラ	DISC, TENSION	
30	100401021	1	イトチヨウシバネ	TENSION SPRING	
31	S31032001	1	イトチヨウシナツト	TENSION NUT	
32	S12441001	1	チヨウシバネウエザガネ	WASHER	
33	012500536	1	アナヒラ5X5	SET SCREW, SOCKET (FT) M5X5	

S. 糸切り関係 / Thread trimmer mechanism

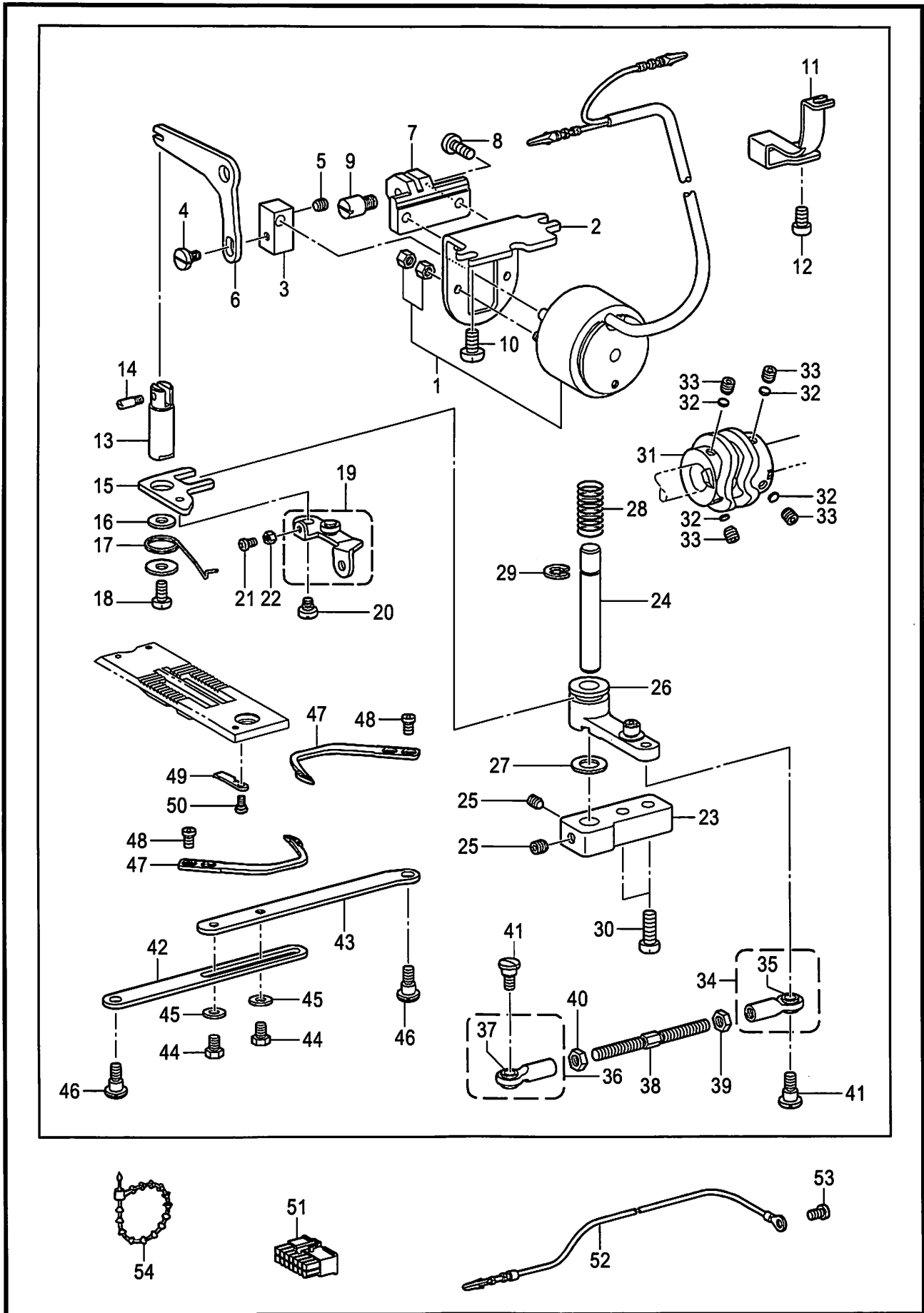

from the library of Diamond Needle Corp

S . 糸切り関係 / Thread trimmer mechanism

REF.NO	CODE	QTY	品名	NAME OF PARTS	RM
1	SA2642001	1	イトキリソレノイド	THREAD TRIMMER SOLENOID	
2	SA2643001	1	ソレノイドシジイタ	SOLENOID BRACKET	
3	SA2644001	1	ソレノイドツギテ	SOLENOID JOINT	
4	SA2645001	1	ダンネジM5	SHOULDER SCREW, M5	
5	012500536	1	アナヒラ5X5	SET SCREW, SOCKET (FT) M5X5	
6	SA2646001	1	ソレノイドレバー	SOLENOID LEVER	
7	SA2728001	1	ソレノイドレバーウケ	SOLENOID LEVERB RACKET	
8	062501016	2	ナベコ5X10	SCREW, PAN M5X10	
9	SA2647001	1	ソレノイドレバージク	SOLENOID LEVER SHAFT	
10	062061012	2	ナベコ6X10	SCREW, PAN M6X10	
11	SA2648001	1	コードオサエ	CORD HOLDER	
12	062060816	1	ナベコ6X8	SCREW, PAN M6X8	
13	SA2651001	1	イトキリジク	DRIVING ROD	
14	148546001	1	プランジャピン	PLUNGER PIN	
15	SA2652101	1	イトキリジクイタ	DRIVING ROD PLATE, TR	
16	SA2860001	1	ザガネ	WASHER	
17	SA2859000	1	イトユルメレバーバネ	SPRING,TENSION RELEASE LEVER	
18	062501016	1	ナベコ5X10	SCREW, PAN M5X10	
19	SA2653001	1	イトユルメレバークミ	TENSION RELEASE LEVER ASSY	
20	SA2655001	1	ダンネジM4	SHOULDER SCREW, M4	
21	062351216	1	ナベコ35X12	SCREW, PAN M3.5X12	
22	021350106	1	1シユナツト35	NUT, 1 M3.5	
23	SA2657001	1	シユレバージクササエ	MAIN LEVER SUPPORT SHAFT	
24	SA2658001	1	シユレバージク	MAIN LEVER SHAFT	
25	012060636	2	アナヒラ6X6	SET SCREW, SOCKET (FT) M6X6	
26	SA2659001	1	シユレバークミ	MAIN LEVER ASSY, KNIFE	
27	148559100	1	ゴム	RUBBER	
28	S07509001	1	シユレバーバネ	MAIN LEVER SPRING	
29	048070342	1	トメワE7	RETAINING RING, E7	
30	062061616	2	ナベコ6X16	SCREW, PAN M6X16	
31	SA2661001	1	イトキリカム	THREAD TRIMMER CAM	
32	SA2378001	4	カンザ4.8	SPACER,4.8	
33	S25236001	4	アナヒラ6X10ホソメ	SET SCREW, SOCKET (FT) M6X10	
34	SA2663001	1	タマツギテRクミ	ROUND JOINT ASSY, R	
35	141331002	1	キユウメンブシユ	BUSH	
36	SA2665001	1	タマツギテLクミ	ROUND JOINT ASSY, L	
37	141331002	1	キユウメンブシユ	BUSH	
38	SA2667001	1	ナガサチヨウセツレンカン	L-ADJUSTING CONNECTING ROD	
39	021060306	1	3シユナツト6	NUT, 3 M6	
40	SA2668001	1	ナツト6ヒダリ	NUT,M6 LEFT	
41	SA2669001	2	タマツギテダンネジ	SHOULDER SCREW, SM5.95-28	
42	SA2672001	1	イトキリレンカンR	T-TRIMMER CONNECTING ROD, R	
43	SA2673001	1	イトキリレンカンL	T-TRIMMER CONNECTING ROD, L	
44	017500812	2	ボルト5X8	BOLT, M5X8	
45	025050236	2	ヒラザガネチユウ5	WASHER, PLAIN M 5	
46	SA2645001	2	ダンネジM5	SHOULDER SCREW, M5	
47	S07526201	2	イドウハ	MOVABLE KNIFE	
48	148536001	4	シメネジ4.37	SCREW, W/SOCKET SM4.37-40X4.2	
49	S07527001	2	コテイハ	FIXED KNIFE	
50	148539101	2	ダンネジ2.38	SHOULDER SCREW, SM2.38	
51	S38687000	1	コネクタ5557-14R	CONNECTOR, 5557-14R	
52	SA1998001	1	アースセンクミ	GROUND WIRE ASSY	
53	062500816	1	ナベコ5X8	SCREW, PAN M5X8	
54	340400001	2	ユニタイバンド	BEAD BAND	

from the library of Diamond Needle Corp

T. 糸払い関係 / Thread wiper mechanism

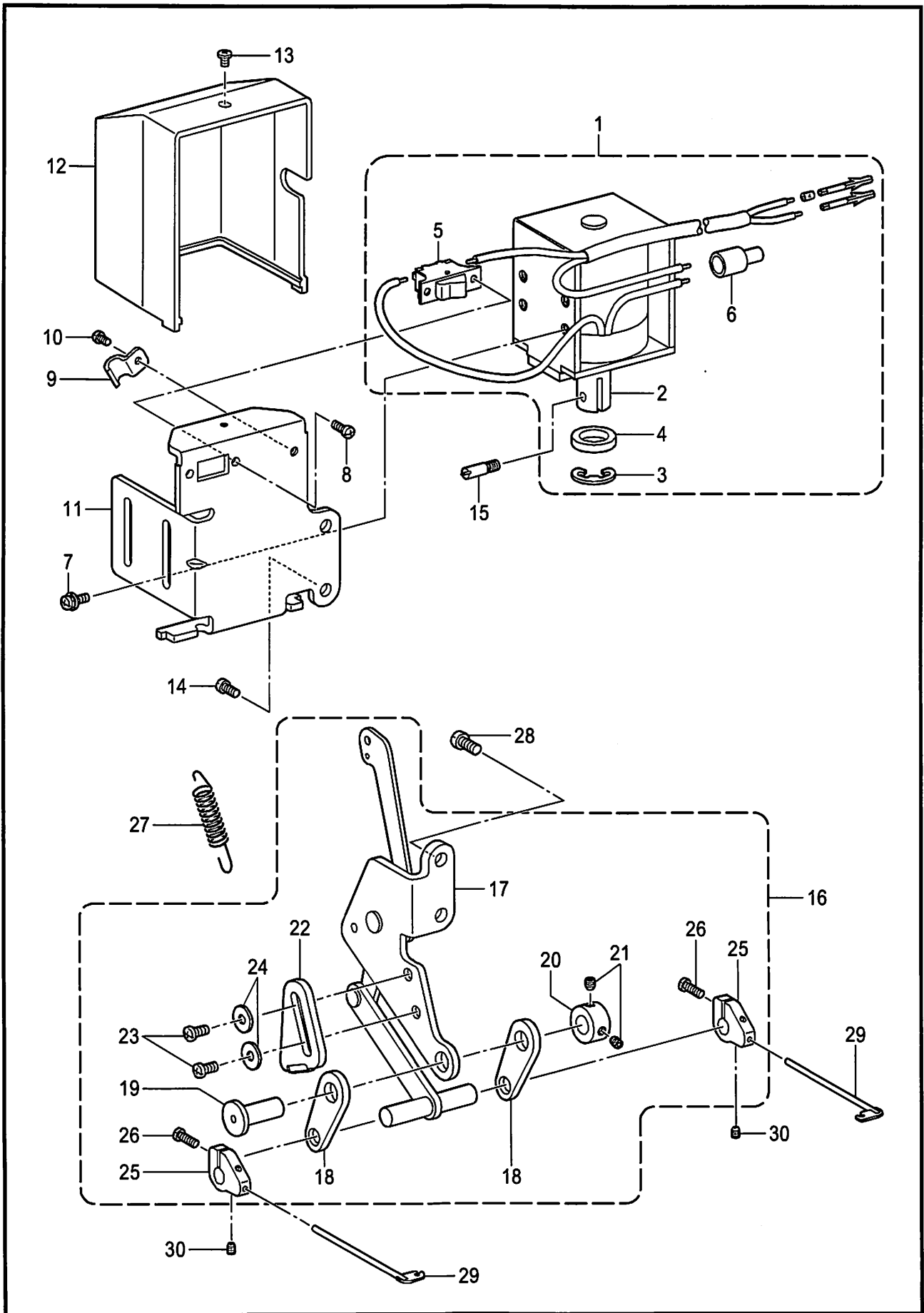

from the library of Diamond Needle Corp

T . 糸払い関係 / Thread wiper mechanism

REF.NO	CODE	Q'TY	品名	NAME OF PARTS	RM
1	SA2680001	1	イトハライソレノイドクミ	THREAD WIPER SOLENOID ASSY	
2	148511001	1	プランジャ	PLUNGER	
3	048090342	1	トメワE9	RETAINING RING, E9	
4	S38426000	1	プランジャゴム	PLUNGER RUBBER	
5	S02664001	1	イトハライスイッチ	THREAD WIPER SWITCH	
6	S02665000	1	ヘイタンセツゾクシ	TERMINAL CONNECTOR	
7	S39048001	4	ナベザクミM4X10	SCREW, PAN (S/P W) M4X10	
8	062300616	2	ナベコ3X6	SCREW, PAN M3X6	
9	140647101	1	コードオサエ	CORD HOLDER	
10	062400616	1	ナベコ4X6	SCREW, PAN M4X6	
11	SA2732001	1	ソレノイドホジイタ	SOLENOID HOLDING PLATE	
12	SA2696001	1	ソレノイドカバー	SOLENOID COVER	
13	060400516	1	バインド4X5	SCREW, BIND M4X5	
14	062501016	2	ナベコ5X10	SCREW, PAN M5X10	
15	148546001	1	プランジャピン	PLUNGER PIN	
16	SA2682001	1	イトハライリンククミ	THREAD WIPER SOLENOID ASSY	
17	SA2683001	1	ソレノイドリンク	SOLENOID LINK	
18	S07549101	2	イトハライリンクC	THREAD WIPER LINK, C	
19	S07550001	1	リンクジク	LINK STUD	
20	SA2504001	1	セットカラー	SET SCREW COLLAR	
21	012500536	2	アナヒラ5X5	SET SCREW, SOCKET (FT) M5X5	
22	S38421001	1	ストツパ	STOPPER	
23	062500816	2	ナベコ5X8	SCREW, PAN M5X8	
24	025050236	2	ヒラザガネチユウ5	WASHER, PLAIN M 5	
25	S07552001	2	イトハライウケ	THREAD WIPER SUPPORT	
26	062661212	2	ナベコ318-40X12	SCREW, PAN SM3.18-40X12	
27	SA2684001	1	イトハライバネ	THREAD WIPER SPRING	
28	062501016	2	ナベコ5X10	SCREW, PAN M5X10	
29	S07553001	2	イトハライ	THREAD WIPER	
30	S07424001	2	トメネジ3.18	SET SCREW, W/SOCKET SM3.18X4	

U1 . コントロールボックス、モータ関係 / Control box and motor mechanism

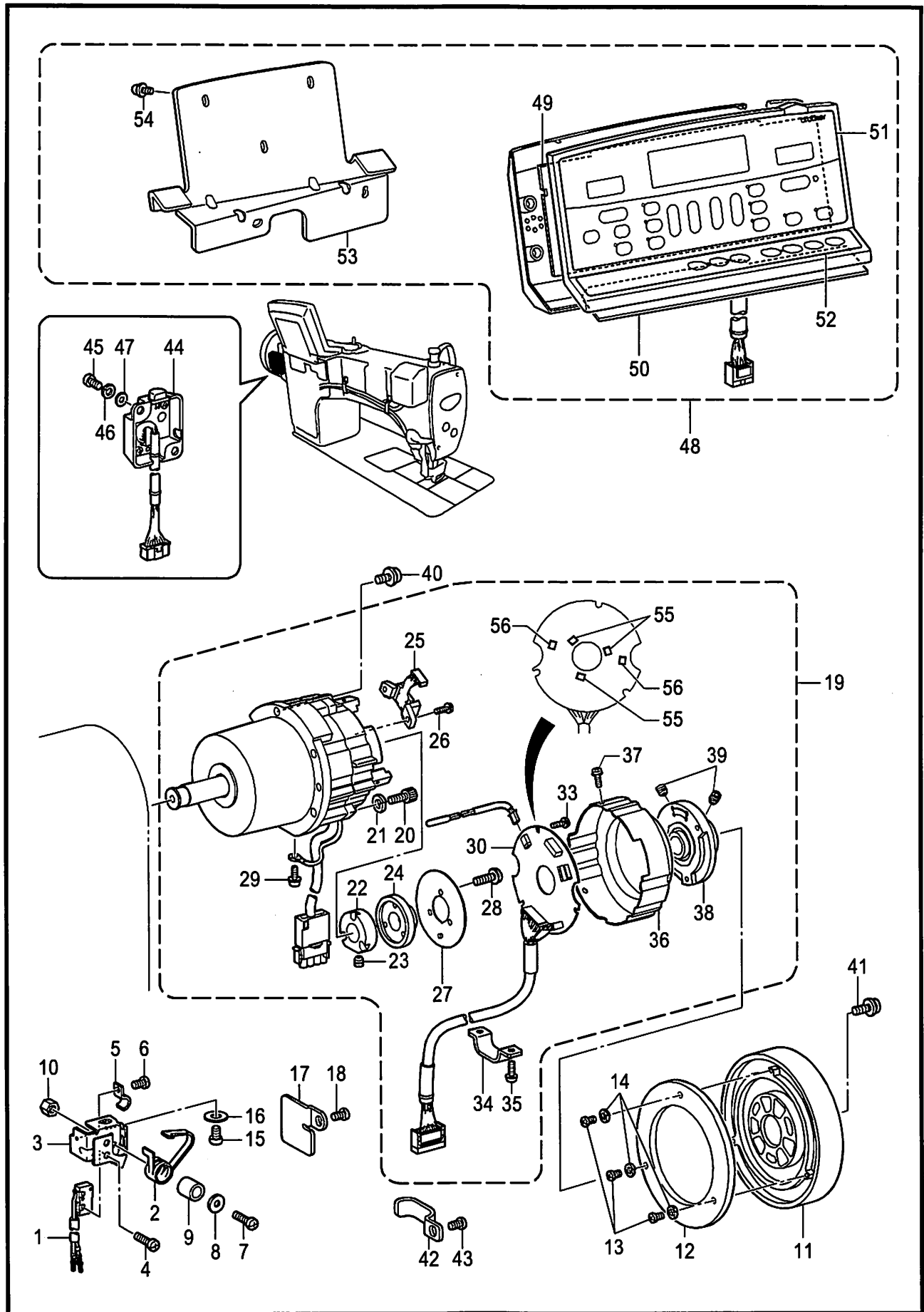

from the library of Diamond Needle Corp

U1 . コントロールボックス、モータ関係 / Control box and motor mechanism

REF.NO	CODE	Q'TY	品名	NAME OF PARTS	RM
1	SA1385001	1	マイクロスイッチクミ	MICRO SWITCH ASSY	
2	S38744101	1	スイッチイタバネ	SWITCH PLATE SPRING	
3	SA2686001	1	スイッチダイ	SWITCH BASE	
4	062020806	2	ナベコ2X8	SCREW, PAN M2X8	
5	140647101	1	コードオサエ	CORD HOLDER	
6	062400616	1	ナベコ4X6	SCREW, PAN M4X6	
7	062401216	1	ナベコ4X12	SCREW, PAN M4X12	
8	026040236	1	ヒラザガネミガキ4	WASHER, PLAIN M 4	
9	154514001	1	スペーサ	SPACER	
10	021400106	1	1シユナツト4	NUT, 1 M4	
11	SA4040001	1	プーリCDD	PULLEY,CDD	
12	SA3175001	1	ガードプレート	GUARD PLATE	
13	062300616	3	ナベコ3X6	SCREW, PAN M3X6	
14	028030246	3	バネザガネ2-3	WASHER, SPRING 2-3	
15	062060812	1	ナベコ6X8	SCREW, PAN M6X8	
16	025060136	1	ヒラザガネシヨウ6	WASHER, PLAIN S 6	
17	SA2712001	1	コードオサエ	CORD HOLDER	
18	062500816	1	ナベコ5X8	SCREW, PAN M5X8	
19	J80990001	1	モータクミCDD-HT	MOTOR ASSY, CDD-HT	
20	018501632	3	アナボルト5X16	BOLT, SOCKET M5X16	
21	028050242	3	バネザガネ2-5	WASHER, SPRING 2-5	
22	J03955001	1	ドラムコテイCDD	DRUM CDD	
23	014400632	2	アナクボミ4X6	SET SCREW, SOCKET (CP) M4X6	
24	J03956001	1	ジシヤク180P36	MAGNET 180P36	
25	J03957001	1	MRセンサクミ180P	MR SENSOR ASSY 180P	
26	0A4300805	2	+ナベザクミ3X8DA	SCREW, PAN (S/P WASHER) M3X8	
27	J03958001	1	シヤヘイイタCDD	SHIELD PLATE CDD	
28	0A4261005	3	+ナベザクミ26X10DA	SCREW, PAN (S/P WASHE) M2.6X10	
29	0A4401005	1	+ナベザクミ4X10DA	SCREW, PAN (S/P WASHE) M4X10	
30	J80971001	1	CDD-ENCキバンクミ	PCB ASSY, CDD-ENC	
33	0A5300606	3	+ナベザクミ3X6DB	SCREW, PAN (S/P WASHER) M3X6	
34	J04230001	1	コードオサエCDD-HT	CORD HOLDER, CDD-HT	
35	0A4401005	2	+ナベザクミ4X10DA	SCREW, PAN (S/P WASHE) M4X10	
36	J04296001	1	エンコーダカバーCDD#2	ENCODER COVER, CDD #2	
37	0A4300805	3	+ナベザクミ3X8DA	SCREW, PAN (S/P WASHER) M3X8	
38	J03964001	1	プーリリツケタイクミCDD	PULLEY HOLDER ASSY CDD	
39	014500632	2	アナクボミ5X6	SET SCREW, SOCKET (CP) M5X6	
40	SA2354001	5	+ナベセットネジ5X18	SCREW, PAN M5X18	
41	SA3025001	3	ナベザクミ4X10DA	SCREW,PAN(S/P WASHER)M4X10	
42	SA2687001	1	コードオサエ	CORD HOLDER	
43	062500816	1	ナベコ5X8	SCREW, PAN M5X8	
44	SA5200001	1	トウブケンシユツユニット	HEAD DETECTOR UNIT	
45	062500816	2	ナベコ5X8	SCREW, PAN M5X8	
46	028050246	2	バネザガネ2-5	WASHER, SPRING 2-5	
47	026050136	2	ヒラザガネコガタ5	WASHER, PLAIN S 5	
48	BMP2060-0000000-CG40		< 中国向 > G40パネル	< For China Only > G-40-PANEL-CHINA	
48	BMP2060-0000000-0G40		< 中国以外向 > G40パネル	< Exept for China > G-40-PANEL	
48	BMP2060-0000000-EG40		< 欧州向 > G40パネル	< For Europe > G-40-PANEL-EU	
49	J80973001	1	G40パネルキバンクミ	G40 PANEL PCB ASSY	
50	J80974001	1	G40サブキバンクミ	G40 SUB PCB ASSY	
51	J03975001	1	G40パネルカザリイタ1	G40 PANEL SEAT 1	
52	J03976001	1	G40パネルカザリイタ2	G40 PANEL SEAT 2	
53	J04195001	1	パネルトリツケイタ#2	PANEL SETTING PLATE#2	
54	J04273001	3	ナベザクミ4X10DB	SCREW, PAN(S/P WASHER)M4X10	
55	J03983001	3	ホールICE W-400	HALL ELEMENT:ICE-400	
56	J03984001	2	ホールICE W-450	HALL ELEMENT:ICE-450	

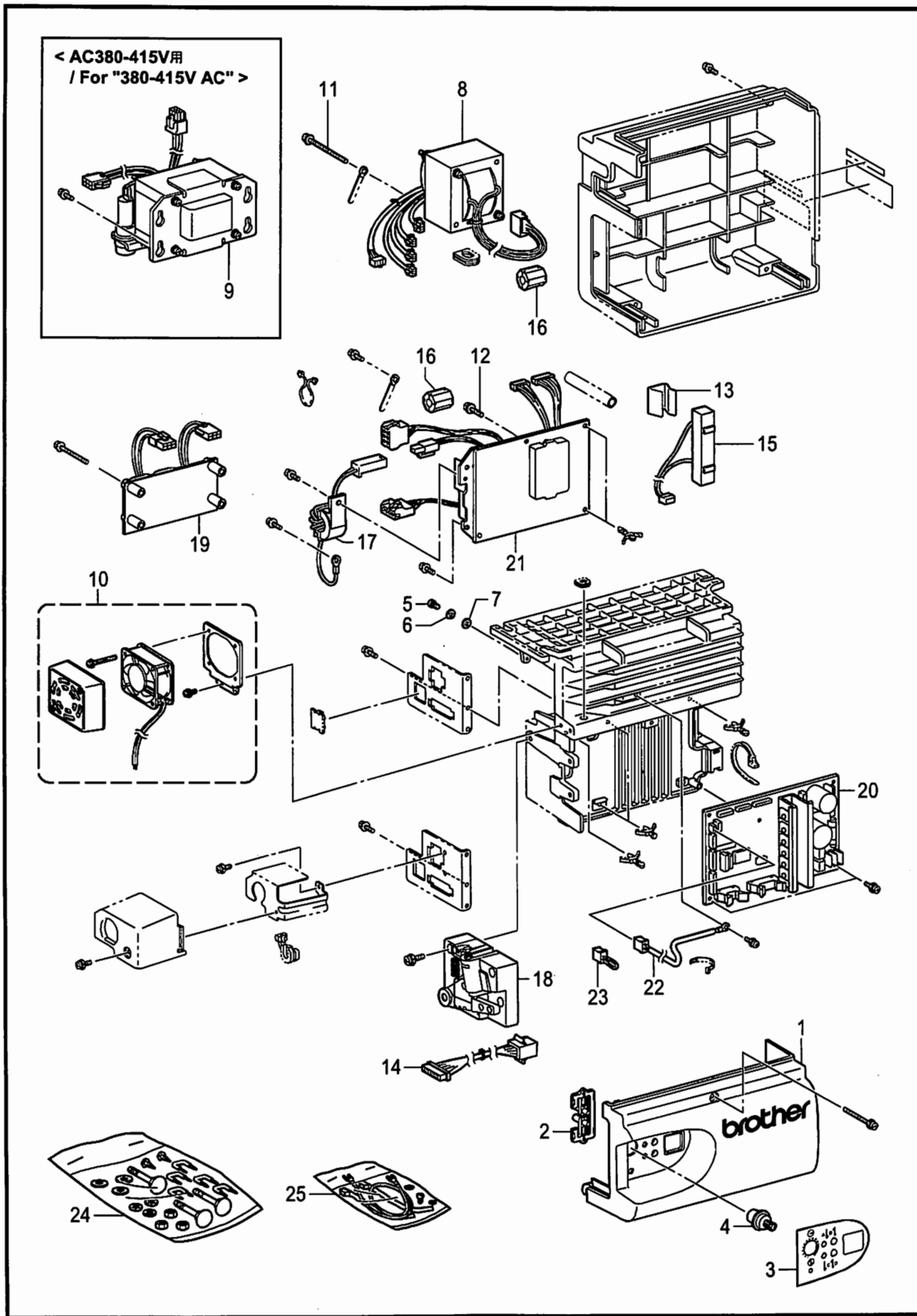

U2 . コントロールボックス関係 / Control box mechanism

REF.NO	CODE	Q'TY	品名	NAME OF PARTS	RM
1	J04393001	1	CDDマイワタGO	FRONT BOX COVER CDD GO	
2	J04438001	1	キートップCDD-GO	KEY TOP	
3	J04440001	1	PカサリイタGO	PANEL SHEET CDD GO	
4	J03733001	1	VツマミLCA	SPEED ADJUST KNOB	
5	062400863	1	ナベコ4X8	SCREW, PAN M4X8	
6	028040245	1	ハネサガネ2-4	WASHER, SPRING 2-4	
7	025040173	1	ヒラサガネシヨウ4	WASHER, PLAIN S 4	
8	J04097001	1	<AC100 - 110V用> トランスCDD-100V	<For " 100 - 110V AC" > TRANSFORMER, CDD-100V	
8	J04098001	1	<AC200 - 230V用> トランスCDD-200V	<For " 200 - 230V AC" > TRANSFORMER, CDD-200V	
9	J03939001	1	<AC380 - 415V用> トランス400V	<For " 380 - 415V AC" > TRANSFORMER, 400V	
10	J04167001	1	DCファンCDDクミ#2	DC FAN ASSY, CDD #2	
11	J01411001	2	<AC100-200Vトランス用> +ナベサガネ4X50DA	<For Transformer of " 100 - 200V AC" > SCREW, PAN (S/P WASHER) M4X50	
12	J00494001	2	+ナベセット4X14DA	SCREW, PAN (S/P WASHER) M4X14	
13	J03739001	1	CRコテイヤ	SPRING PLATE, CR	
14	J04099001	1	フットプラグクミCDD	FOOT PLUG ASSY, CDD	
15	J04100001	1	セメントR40/220クミ#6	CEMENT RESISTOR ASSY, 40/220#6	
16	J04468001	2	<欧州向用> コアESD-SR-120	<For Europe> CORE:SD-SR-120	
17	J02725001	1	アースインダクタ#2	EARTH INDUCTOR	
18	J80967001	1	<前一段, 後一段タイプ> フミユニットCDD-コクホ	<Type forward 1 step, backward 1 step > TREADLE UNIT ASSY, CDD G	
18	J80968001	1	<前二段, 後二段タイプ> フミユニットCDD-ユホ	<Type forward 2 step, backward 2 step > TREADLE UNIT ASSY, CDD H	
19	J80970001	1	<欧州向用> CEフィルタキバンクミ	<For Europe> CE FILTER PCB ASSY	
20	J80964201	1	SキバンCDDクミ#GO	CONTROL PCB ASSY CDD#GO	
21	J80965001	1	<110V AC用> DキバンCDD1-110Vクミ	<For " 110V AC" > POWER PCB ASSY, CDD 1-110V	
21	J80966101	1	<220 - 240V AC用> DキバンCDD1-230Vクミ	<For " 220 - 240V AC" > POWER PCB ASSY CDD 1-230V	
22	J04169001	1	<400V AC用> CDDサーミスタ#2	<For " 400V AC" > THERMISTOR, CDD #2	
23	J04168001	1	<400V AC以外用> ショートコネクタ	<For Others> SHORT CONNECTOR	
24	J04210001	1	カクネ8X65 クミ	BOLT ASSY, SQUARE M8X65	
25	J04243001	1	アースコードネジタイクミ	EARTH CORD SCREW TIE ASSY	

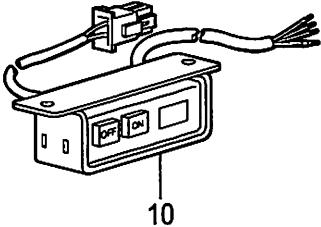
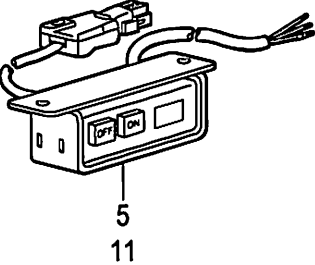
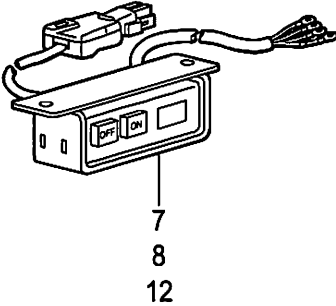
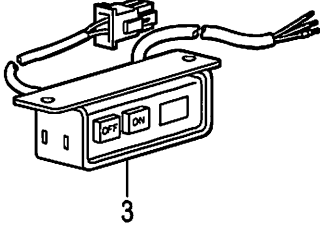
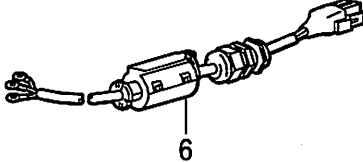
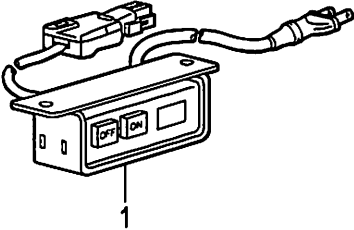

from the library of Diamond Needle Corp

V. 電装品関係 / Power supply equipment mechanism

REF.NO	CODE	Q'TY	品名	NAME OF PARTS	RM
1	J04086001	1	デンSWクミ1-100V#6	POWER SWITCH ASSY, 1-100V #6	
3	J04469001	1	デンSWクミ1-110V#8	POWER SWITCH ASSY, 1-110V #8	
5	J04093001	1	デンSWクミ1-240V#6	POWER SWITCH ASSY, 1-240V #6	
6	J04134001	1	デンPGクミ1-240V#6	POWER PLUG ASSY, 1-240V #6	
7	J04096001	1	デンSWクミ3-400V#6	POWER SWITCH ASSY, 3-400V #6	
8	J04149001	1	デンSWクミ3-200V#6	POWER SWITCH ASSY, 3-200V #6	
10	J04470001	1	デンSWクミ3-240V#8	POWER SWITCH ASSY, 3-240V #8	
11	J04251001	1	デンSWクミ1-240V#CCC	POWER SWITCH ASSY, 1-240V #CCC	
12	J04255001	1	デンSWクミ3-400V#CCC	POWER SWITCH ASSY, 3-400V #CCC	

T-8452A-515

* 上記の部品は、仕様別部品表で確認後注文して下さい。

* Check the replacement parts product number in the Different parts list before ordering the above parts.

Sp1. 仕様別部品一覧表 (電装品関係) / Different parts list (Power supply equipment mechanism)

REF.	単相 / Single phase				三相 / Three phase		
	100V AC	110V AC	220V AC	230V AC CE	200V AC	220V AC	380V AC
V-1	J04086001 < For Japan >						
V-3		J04469001 < For USA & Mexico >					
V-5			J04093001 <For General of Asia & North africa>				
V-6				J04134001 Power SW-less < For Europe >			
V-7							J04096001 < For General of Asia & North africa >
V-8					J04149001 < For Japan >		
V-10						J04470001 < For USA & Mexico >	
V-11			J04251001 < For China >				
V-12							J04255001 < For China >

T-8452A-Sp1

W. 電磁押え上げセット関係 (オプション部品) / Presser foot lifting solenoid set (Option parts)

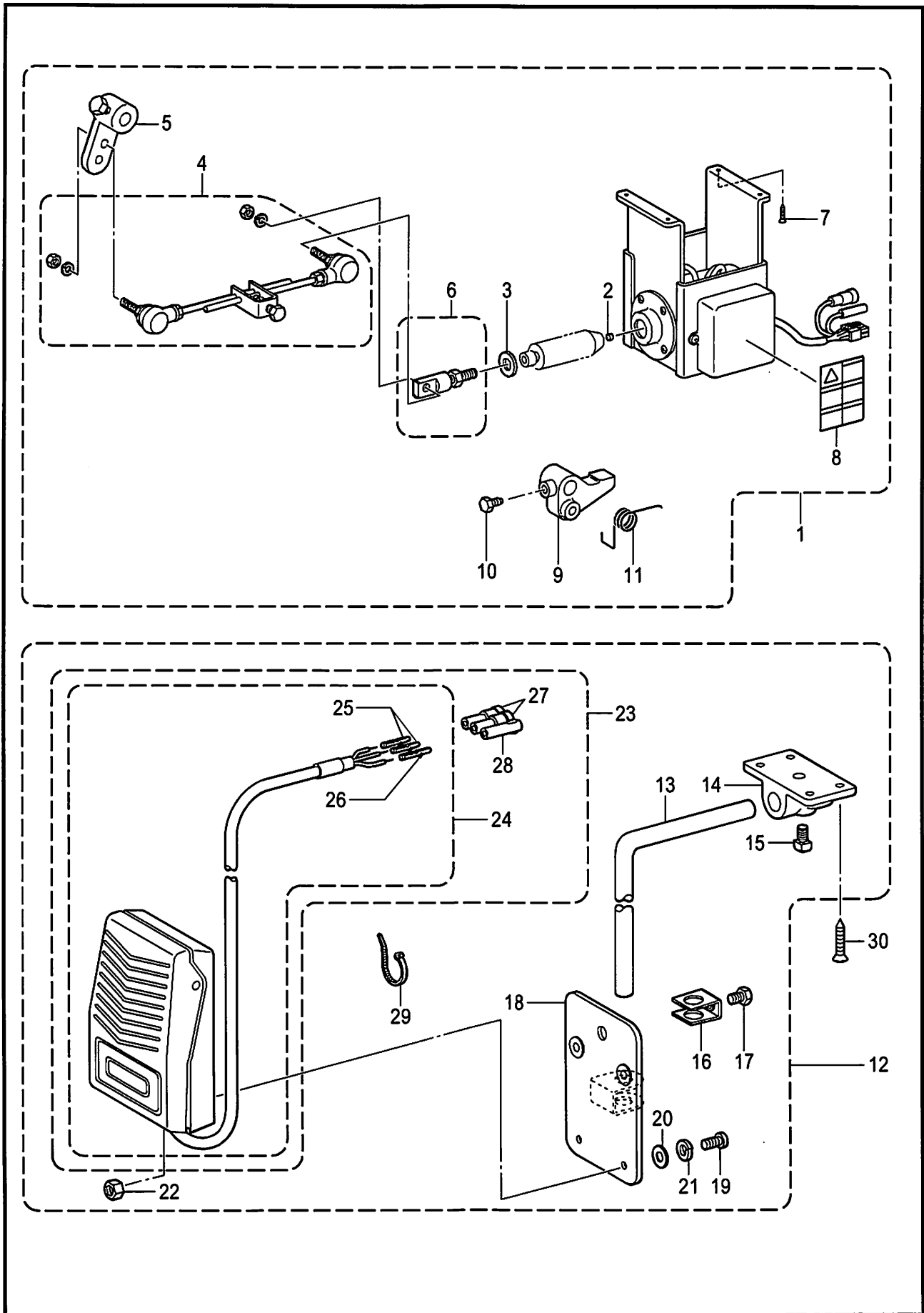

from the library of Diamond Needle Corp

W . 電磁押え上げセット関係(オプション部品)/ Presser foot lifting solenoid set (Option parts)

REF.NO	CODE	QTY	品名	NAME OF PARTS	RM
1	SA2707001	1	デンジオサエアゲセットD2	P-FOOT LIFTER SOLENOID SET, D2	
2	S54025001	1	クッション	CUSHION	
3	S54024001	1	クッションリング	CUSHION RING	
4	S42198051	1	オサエアゲロッドクミ	PRESSER FOOT LIFTER ROD ASSY	
5	S42199051	1	オサエアゲレバークミ	P-FOOT LIFTER LEVER ASSY	
6	S41955051	1	ロッドツギテクミ	ROD JOINT ASSY	
7	S42200051	4	モクネジ	WOOD SCREW	
8	S38351001	1	コウオンラベル	LABEL, HIGH TEMP	
9	S10550001	1	オサエアゲリンク	PRESSER BAR LIFTER LINK	
10	146367001	1	ボルト5.95	BOLT, SM5.95	
11	S07729001	1	ネジリバネ	SPRING, TWIST	
12	S07045009	1	ヒザスイツチクミ	KNEE LIFTER SWITCH ASSY	
13	142026003	1	ヒザスイツチタテジク	KNEE SWITCH SHAFT	
14	142027001	1	ヒザスイツチタテジクウケ	BRACKET	
15	100463001	1	4カクボルト7.94	BOLT, SQUARE SM7.94	
16	114967001	1	ヒザアテストップ	KNEE LIFTER PLATE STOPPER	
17	110087001	1	ボルト5.95	BOLT, SM5.95-28X8	
18	S07027001	1	ヒザスイツチトリツケイタ	K-LIFTER SWITCH SETTING PLATE	
19	062401006	4	ナベコ4X10	SCREW, PAN M4X10	
20	025040233	4	ヒラザガネチユウ4	WASHER, PLAIN M 4	
21	028040243	4	バネザガネ2-4	WASHER, SPRING 2-4	
22	021400164	4	1シユナツト4	NUT, 1 M4	
23	S07030009	1	スイツチコードクミ	SWITCH & HARNESS ASSY	
24	S07031009	1	フットスイツチクミ	FOOT SWITCH ASSY	
25	143549000	2	ピンターミナルオス	TERMINAL PIN, MALE	
26	143548000	1	ピンターミナルメス	TERMINAL PIN, FEMALE	
27	146046000	2	ナイロンコネクタ	NYLON CONNECTOR	
28	146194000	1	ナイロンコネクタ	NYLON CONNECTOR	
29	149799000	1	タイラツプS	BEAD BAND, S	
30	034422503	1	+2サラモク41X25	WOOD SCREW, FLAT 2 M4.1X25	

Z1 . 付属品関係 / Accessories

11: -□□3用 / For "-□□3"
 -□□5用 / For "-□□5"

10: -□□3用 / For "-□□3"
 -□□5用 / For "-□□5"

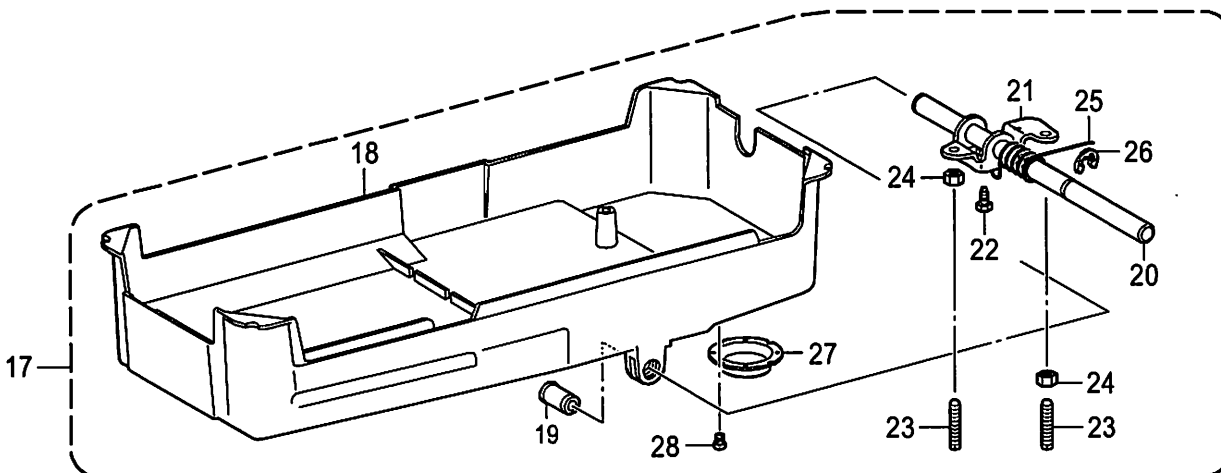
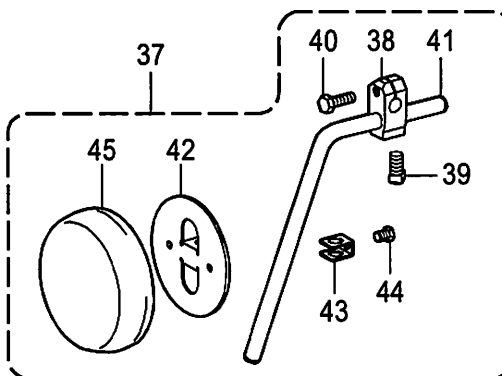
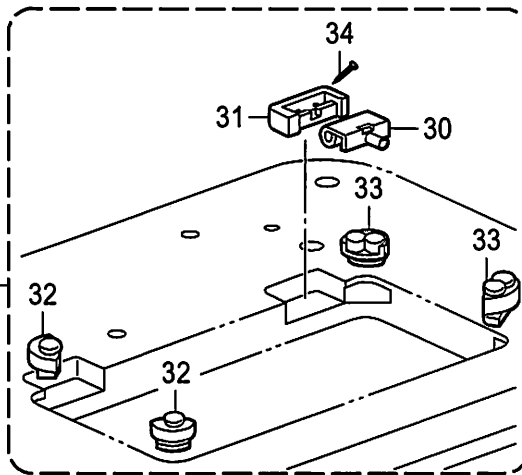
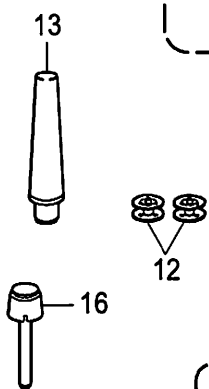
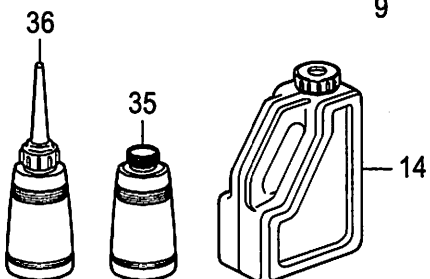
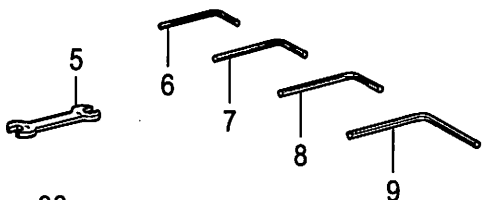
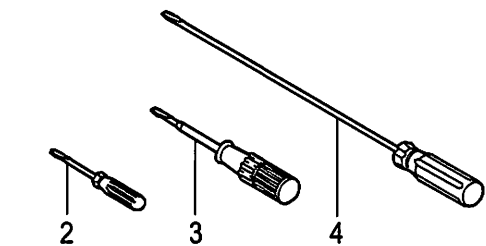
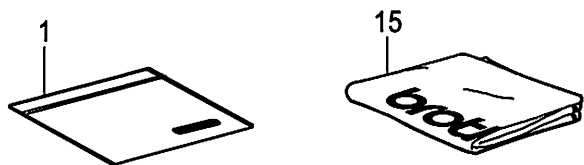

from the library of Diamond Needle Corp

Z1 . 付属品関係 / Accessories

REF.NO	CODE	QTY	品名	NAME OF PARTS	RM
1	122991001	1	フゾクヒンポリフクロ	ACCESSORY BAG	
2	142443001	1	ネジマワシ1.9X52	SCREW-DRIVER, 1.9X52	
3	118837001	1	ネジマワシ3.4X70	SCREW-DRIVER, 3.4X70	
4	S17774001	1	ネジマワシ4.7X250	SCREW-DRIVER, 4.7X250	
5	100887001	1	スパナ8X9	WRENCH, 8X9	
6	142002001	1	6カクボウスパナ2	HEXAGONAL WRENCH, 2	
7	154125001	1	6カクボウスパナ2.5	HEXAGONAL WRENCH, 2.5	
8	142721001	1	6カクボウスパナ3	HEXAGONAL WRENCH, 3	
9	149570001	1	6カクボウスパナ5	HEXAGONAL WRENCH, 5	
			<-□□3用>	<For"-□□3">	
10	SA1752014	1	107415/ハリ4コイリクミ	NEEDLE 4PIECE ASSY, 107415	
11	107415014	4	ミシンハリDPX5	NEEDLE, DPX5	
			<-□□5用>	<For"-□□5">	
10	SA1752022	1	107415/ハリ4コイリクミ	NEEDLE 4PIECE ASSY, 107415	
11	107415022	4	ミシンハリDPX5	NEEDLE, DPX5	
12	S01928151	2	ボビン	BOBBIN	
13	100477009	1	マクラ	HEAD REST	
14	S55663001	1	オイルタンククミ	OIL TANK ASSY	
15	144226001	1	トウブカバー	HEAD COVER	
16	145573000	1	ヒザアゲオシボウ	KNEE LIFTER COMPLYING BAR	
17	SA2691101	1	アブラウケクミ	OIL PAN ASSY	
18	SA2692101	1	アブラウケ	OIL PAN	
19	149578000	2	ヨコジクブツシュ	BUSH	
20	SA2582001	1	ヒザアゲヨコジク	KNEE LIFTER SHAFT	
21	SA2590001	1	ヒザアゲ	KNEE LIFTER	
22	S25344001	1	ボルト6	BOLT, M6	
23	S25475001	2	トメネジ6	SET SCREW, M6X19	
24	021060306	2	3シユナツト6	NUT, 3 M6	
25	S15889001	1	ヒザアゲネジリバネ	TWIST SPRING	
26	146293001	1	トメワE10	RETAINING RING, E10	
27	153230101	1	オイルニガシグチ	DRAIN	
28	S23418002	2	シメネジ4X5	SCREW, M4X5	
29	SA1969001	1	ラバ-ヒンジクミ	RUBBER HINGE ASSY	
30	143882001	2	トウブヒンジ	HEAD HINGE	
31	143910009	2	トウブヒンジウケゴム	RUBBER CUSHION	
32	SA1962001	2	トウブシキゴム	HEAD CUSHION	
33	SA1963001	2	トウブシキゴム	HEAD CUSHION	
34	109714000	4	クギ	NAIL	
35	114486002	1	ポリオイラータイ	OILER	
36	114483002	1	ポリオイラークミ	OILER ASSY	
37	S38300001	1	ヒザアテクミ	KNEE LIFTER ASSY	
38	146039001	1	ヒザアテツギテ	KNEE LIFTER BRACKET	
39	100463001	1	4カクボルト7.94	BOLT, SQUARE SM7.94	
40	017762013	1	ボルト595-28X20	BOLT, SM5.95-28X20	
41	S38278001	1	ヒザアゲタテジク	KNEE LIFTER BAR	
42	S34756001	1	ヒザアテ	KNEE LIFTER PLATE	
43	114967001	1	ヒザアテストップパ	KNEE LIFTER PLATE STOPPER	
44	110087001	1	ボルト5.95	BOLT, SM5.95-28X8	
45	S31885001	1	ヒザアテカバー	KNEE LIFTER PLATE COVER	

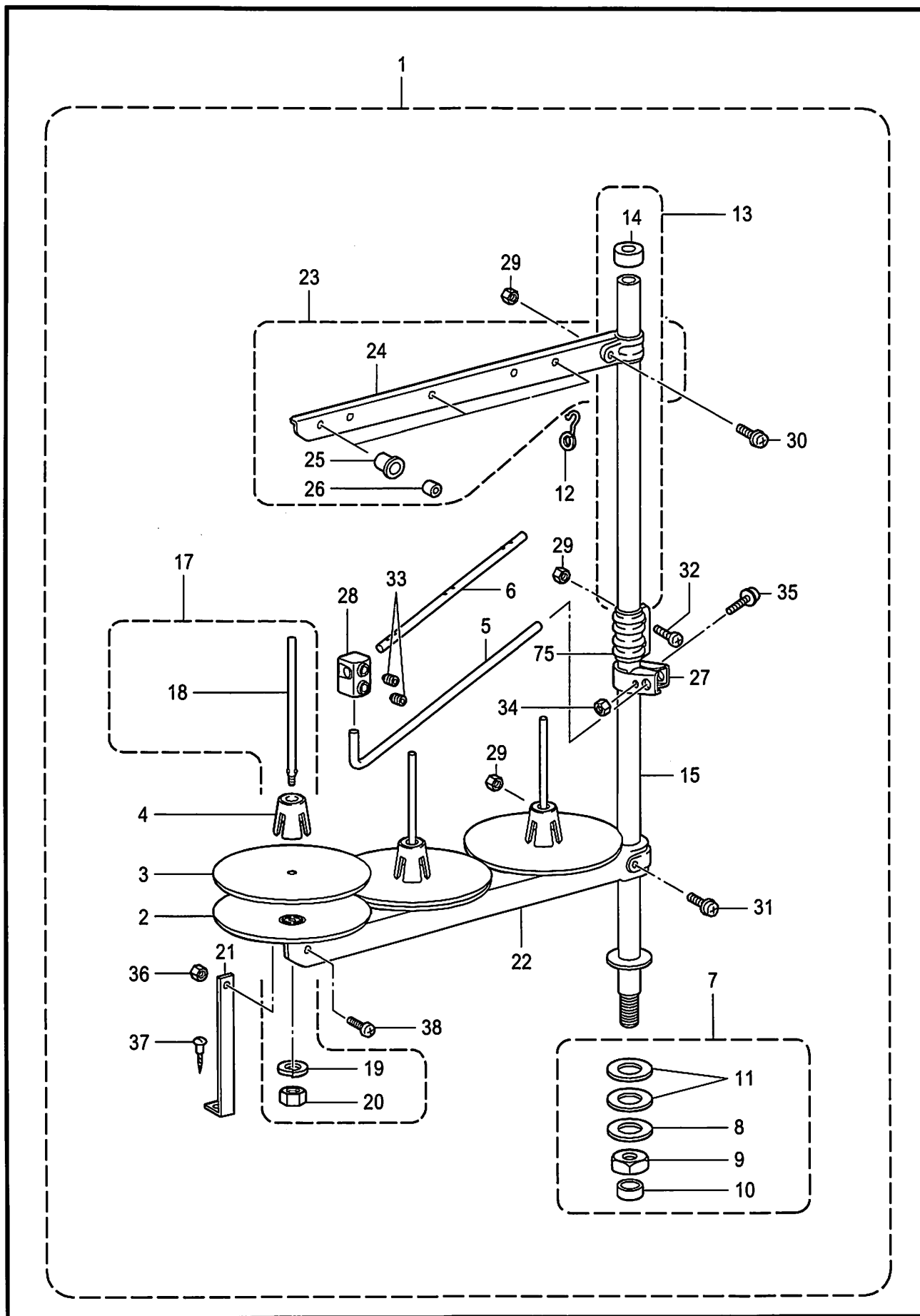

from the library of Diamond Needle Corp

Z2 . 付属品関係 / Accessories

REF.NO	CODE	Q'TY	品名	NAME OF PARTS	RM
1	S07558309	1	イトタテダイクミ3DRTHF	COTTON STAND ASSY, 3DRTHF	
2	S51283001	3	ウケザラ	SPOOL STAND BASE	
3	150182000	3	スプールマット	SPOOL MAT	
4	S51282101	3	スプールクッション	SPOOL CUSHION	
5	S04109001	1	イトアンナイササエボウ	THREAD GUIDE SUPPORT BAR	
6	142997001	1	イトアンナイ3	THREAD GUIDE, 3	
7	SA2867001	1	パイプDネジセットB	PIPE D SCREW SET, B	
8	150206002	1	ヒラザガネ16	WASHER, PLAIN 16	
9	S38648001	1	6カクナツU5/8	NUT, U5/8-28	
10	150174000	1	コラムキャップ	COLUMN CAP	
11	S01005000	2	イトタテゴム	RUBBER WASHER	
12	S02747101	1	イトカケバネ	SPRING	
13	S40639001	1	コラムパイプキャップツキ	COLUMN PIPE W/CAP	
14	150174000	1	コラムキャップ	COLUMN CAP	
15	156112003	1	コラムパイプD	COLUMN PIPE, D	
16	150173003	1	コラムジョイント	COLUMN JOINT	
17	S21798001	3	スプールネジセット	SPOOL & SCREW SET	
18	150179002	3	スプールジクB	SPOOL SHAFT, B	
19	028050246	3	バネザガネ2-5	WASHER, SPRING 2-5	
20	021500106	3	1シュナツ5	NUT, 1 M5	
21	150188009	1	スプールホルダーササエA	SPOOL HOLDER SUPPORT, A	
22	S02779009	1	スプールホルダー3	SPOOL HOLDER, 3	
23	S02788009	1	スレツドハンガークミ3	THREAD HANGER ASSY, 3	
24	S02789009	1	スレツドハンガー3	THREAD HANGER, 3	
25	150183000	3	イトカケハンガーダイ	THREAD HANGER BASE	
26	142990001	3	スレツドブツシユ	THREAD BUSH	
27	150185009	1	イトアンナイホルダー	THREAD GUIDE HOLDER	
28	138843001	1	ササエボウツギテ	JOINT	
29	021500106	4	1シュナツ5	NUT, 1 M5	
30	S37038001	1	ナベコヒラザ5X14	SCREW, PAN(S/P WASHER) M5X14	
31	S37037001	1	ナベコヒラザ5X32	SCREW, PAN (S/P WASHER) M5X32	
32	062501406	2	ナベコ5X14	SCREW, PAN M5X14	
33	014060632	2	アナクボミ6X6	SET SCREW, SOCKET (CP) M6X6	
34	021500106	1	1シュナツ5	NUT, 1 M5	
35	S37037001	1	ナベコヒラザ5X32	SCREW, PAN (S/P WASHER) M5X32	
36	021500106	1	1シュナツ5	NUT, 1 M5	
37	031452206	1	マルモク45X22	WOOD SCREW, ROUND M4.5X22	
38	062501006	1	ナベコ5X10	SCREW, PAN M5X10	

Wa. 警告ラベル / Warning labels

警告ラベル / Warning labels	品名 / Name of parts	Size(mm)	Code
	<p>ラベル感電6ヶ国 Label, elec. shock 6 lang</p>	<p>50 X 118</p>	<p>J04115-001</p>
	<p>ラベル注意・和英 Label, caution Jpn / Eng</p>	<p>64 X 40</p>	<p>SA2040-001</p>
	<p>ラベル注意・中英 Label, caution Chn / Eng</p>	<p>64 X 40</p>	<p>SA2041-001</p>
	<p>アースマーク Label, grounding</p>	<p>φ 12</p>	<p>S37060-001</p>
	<p>高温ラベル Label, high temp</p>	<p>72 X 59</p>	<p>S38351-001</p>

T-8452A-Wa

Sp.仕様別部品一覧表 / Different parts list

■ かま / Rotary hooks

かまは下記のオプションパーツを用意しています。用途に合わせてご使用ください。

(部品コードは、かまが箱に入ったクミコードです)

The following type of rotary hook are available. Select whichever one is suitable for your application.

(The following parts codes are assigned for the rotary hooks in the boxes.)

●標準 / Normal

	全仕様 / For all type
かま箱組 / Rotary hook assy	SA1683-111
内かま押え / Inner rotary hook holder	S07748-001
調子バネ / Tension spring	151043-001

Ga 1. ゲージ部品一覧表 / Gauge parts list

標準品 / For normal

- * 最大針幅 5/8"(15.9mm)まで出来ます。
- * 糸切り用固定刃(S07527-001)と取付ネジ(148539-101)は、針板には付けてありませんので、必要に応じて別途ご注文して下さい。
- * 3/32 インチのゲージを使用する場合は、DBX1(#7~#18)の針を使用して下さい。
- * A maximum stitch width specification of 5/8"(15.9mm) is available.
- * The thread trimming fixed knife (part no. S07527-001) and the installation screw (part no. 148539-101) are not provided with the needle plate, so they must be ordered separately if required.
- * In case of using the gauge set (3/32"), use needle size DBX1(#7~#18).

針幅 Needle gauge (inch) (mm)	針抱きセット Needle clamp set	針抱き組 Needle clamp assy	針板 Needle plate	送り歯 Feed dog		押え組 Presser foot assy	
			中厚物、厚物用 (-3, -5) For medium & heavy materials	中厚物用 (-3) For medium materials	厚物用 (-5) For heavy materials	中厚物用 (-3) For medium materials	厚物用 (-5) For heavy materials
*3/32 (2.4)	L:S15705-001 R:S15706-001	L:S15707-001 R:S15708-001	159398-001		148697-001		148679-001
1/8 (3.2)	L:S15711-001 R:S15712-001	L:S15713-001 R:S15714-001	155722-001	148698-001	148699-001	S36550-001	S36522-001
5/32 (4.0)	L:S15717-001 R:S15718-001	L:S15719-001 R:S15720-001	155724-001	148700-001	148701-001	148689-001	148683-001
3/16 (4.8)	L:S15723-001 R:S15724-001	L:S15725-001 R:S15726-001	155851-001	148702-001	148703-001	S36554-001	S36556-001
7/32 (5.6)	L:S15729-001 R:S15730-001	L:S15731-001 R:S15732-001	156816-001	156818-001		156819-001	
1/4 (6.4)	L:S15735-001 R:S15736-001	L:S15737-001 R:S15738-001	155853-001	148704-001	148705-001	SA4051-001	SA4050-001
9/32 (7.1)	L:S15741-001 R:S15742-001	L:S15743-001 R:S15744-001	S14530-001	S14532-001	S14533-001	S14534-001	S14536-001
5/16 (7.9)	L:S15747-001 R:S15748-001	L:S15749-001 R:S15750-001	155855-001	149692-001	149691-001	149689-001	149687-001
3/8 (9.5)	L:S15753-001 R:S15754-001	L:S15755-001 R:S15756-001	155857-001	149939-001	149938-001	149942-001	149940-001
7/16 (11.1)	L:S15759-001 R:S15760-001	L:S15761-001 R:S15762-001	S01644-001	S01646-001		S01641-101	
1/2 (12.7)	L:S15765-001 R:S15766-001	L:S15767-001 R:S15768-001	149677-001	149676-001	149675-001	149673-101	149671-101
5/8 (15.9)	L:S15771-001 R:S15772-001	L:S15773-001 R:S15774-001	149954-001	149949-001	149948-001	149952-101	149950-101

空縫い用 / For sewing without material

- * 針板と送り歯と押え組が標準品と異なります。最大送りピッチは4mm以下でご使用下さい。
- * Needle plate, the feed dog and presser foot assembly is different from normal parts.
- * Use gauge components of for sewing without material which have a maximum feed pitch of 4mm or less.

針幅 Needle gauge (inch) (mm)	針抱きセット Needle clamp set	針抱き組 Needle clamp assy	針板 Needle plate	送り歯 Feed dog	押え組 Presser foot assy
3/16 (4.8)	標準品 / Normal	標準品 / Normal	S20901-001	S20905-001	S20903-001
1/4 (6.4)			S10507-001	S10509-101	S10510-001

Ga 1 . ゲージ部品一覧表 / Gauge parts list

T-8452A (糸切り用 / For with Thread trimmer)

標準品 / For Normal

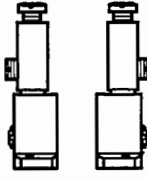
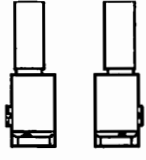
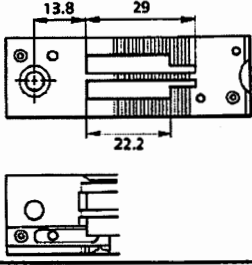
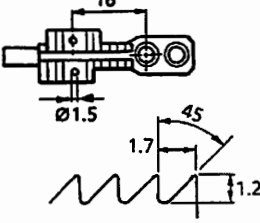
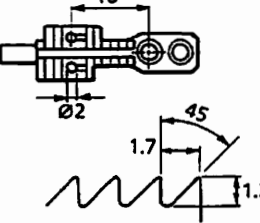
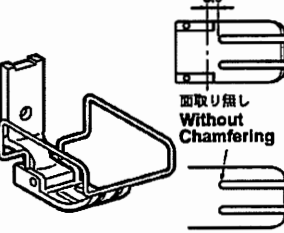
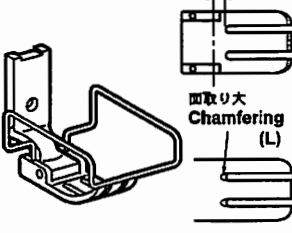
<p>針抱きセット Needle clamp set</p> 	<p>針抱き組 Needle clamp assy</p> 	<p>針板 Needle plate</p> <p>中厚、厚物用(-3, -5) Medium & heavy materials</p> 	
<p>送り歯 Feed dog</p>		<p>押え組 Presser foot assy</p>	
<p>中厚物用(-3) For medium materials</p>	<p>厚物用(-5) For heavy materials</p>	<p>中厚物用(-3) For medium materials</p>	<p>厚物用(-5) For heavy materials</p>
			

空縫い用 / For sewing without material

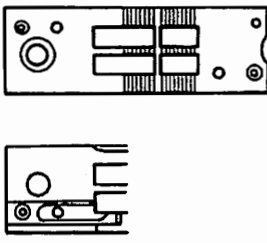
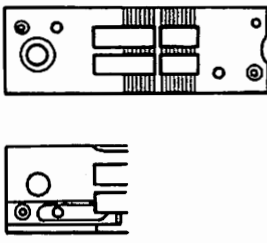
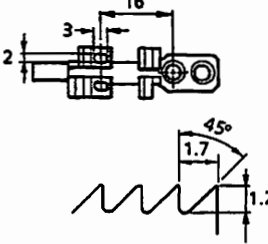
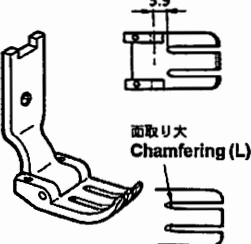
<p>針板 Needle plate</p> 	<p>送り歯 Feed dog</p>	<p>押え組 Presser foot assy</p>
		

Ga 1. ゲージ部品一覧表 / Gauge parts list

T-8452A (糸切り用 / For Thread trimmer)

厚物用 / For heavy materials

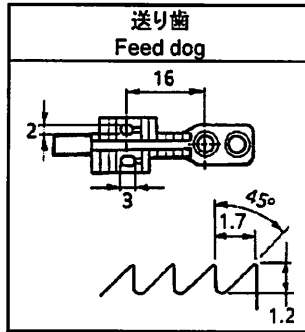

* 送り歯が標準品と異なります。

* The feed dog is different from normal parts.

針幅 Needle gauge (inch) (mm)	針抱きセット Needle clamp set	針抱き組 Needle clamp assy	針板 Needle plate	送り歯 Feed dog	押え組 Presser foot assy
3/16 (4.8)	標準品 / Normal	標準品 / Normal	標準品 / Normal	S07905-001	標準品(-5) / Normal(-5)
1/4 (6.4)				158756-001	

Ga 1. ゲージ部品一覧表 / Gauge parts list

T-8452A (糸切り用 / For with Thread Trimmer)

下送り用 / For Drop Feed

- * 糸切り用固定刃 (S07527-001)と取付ネジ (148539-101)は、針板には付けてありませんので、必要に応じて別途ご注文して下さい。
- * 最大針幅 5/8"(15.9mm)まで出来ます。
- * The thread trimming fixed knife (part no. S07527-001) and the installation screw (part no. 148539-101) are not provided with the needle plate, so they must be ordered separately if required.
- * A maximum stitch width specification of 5/8"(15.9mm) is available.

針幅 Needle gauge (inch) (mm)	針抱きセット Needle clamp set	針抱き組 Needle clamp assy	針板 Needle plate	送り歯 Feed dog	押え組 Presser foot assy
1/8 (3.2)	L:S15711-001 R:S15712-001	L:S15713-001 R:S15714-001	S07401-001	S07409-001	S38544-001
3/16 (4.8)	L:S15723-001 R:S15724-001	L:S15725-001 R:S15726-001	S07403-001	S07410-001	S38542-001
1/4 (6.4)	L:S15735-001 R:S15736-001	L:S15737-001 R:S15738-001	S07405-101	S07411-001	S38543-001
5/16 (7.9)	L:S15747-001 R:S15748-001	L:S15749-001 R:S15750-001	S07676-001	S07680-001	S37682-001
3/8 (9.5)	L:S15753-001 R:S15754-001	L:S15755-001 R:S15756-001	S13621-001	S13623-101	S13624-001
1/2 (12.7)	L:S15765-001 R:S15766-001	L:S15767-001 R:S15768-001	S07678-001	S07681-001	S07684-101

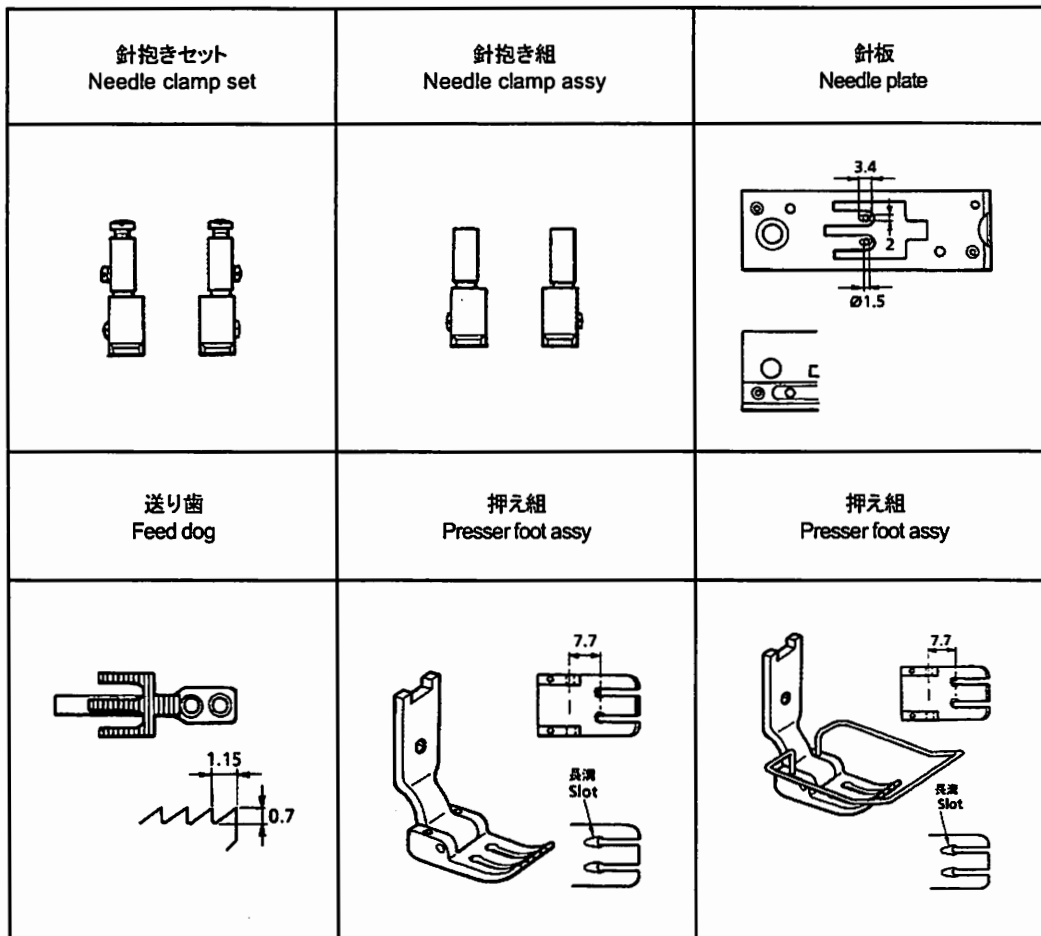

索引 / INDEX

CODE	REF.NO	Page	CODE	REF.NO	Page	CODE	REF.NO	Page	CODE	REF.NO	Page
012060636	C -55	8	025060136	U1 -16	40	062400616	K1 -27	22	0A4261005	U1 -28	40
	F -32	14	025060236	P -69	30		K1 -29	22	0A4300805	U1 -26	40
	G -15	16	025100132	F -36	14		K1 -32	22		U1 -37	40
	J -7	18	025710132	K1 -11	20		P -64	30	0A4400806	P -46	28
	J -26	18	026040236	U1 -8	40		T -10	38	0A4401005	U1 -29	40
	Q -42	32	026050136	U1 -47	40		U1 -6	40		U1 -35	40
	S -25	36	028030246	U1 -14	40	062400812	K1 -35	20	0A5300606	U1 -33	40
012061036	B -25	4	028040242	B -22	4		K1 -35	22	0A5501006	P -24	28
012061832	E -17	12	028040243	W -21	46	062400863	U2 -5	42	100032004	L -8	24
012500536	E -25	12	028040245	U2 -6	42	062401006	W -19	46	100328001	F -25	14
	K1 -15	20	028050242	U1 -21	40	062401216	R -17	34	100401021	R -30	34
	K1 -15	22	028050246	U1 -46	40		U1 -7	40	100463001	W -15	46
	Q -31	32		Z2 -19	50	062401616	P -54	28		Z1 -39	48
	R -8	34	031452206	Z2 -37	50	062403512	B -21	4	100477009	Z1 -13	48
	R -13	34	034422503	W -30	46	062500616	A -12	2	100887001	Z1 -5	48
	R -33	34	047301842	D -11	10		H -9	16	104449001	A -4	2
	S -5	36	048030342	E -15	12		H -11	16	104450101	P -19	28
	T -21	38		E -39	12		H -13	16		P -45	28
013660412	L -3	24	048040342	R -2	34		P -57	28		P -61	28
014060632	Z2 -33	50		R -14	34		R -27	34	104821001	F -43	14
014080831	C -43	8	048060142	G -9	16	062500812	G -6	16	104833001	D -2	10
014400432	D -30	10	048060342	F -18	14	062500816	A -25	2	107155001	C -39	6
014400632	U1 -23	40	048070342	S -29	36		B -27	4	107415014	Z1 -11	48
	U1 -39	40	048080342	F -35	14		B -32	4	107415022	Z1 -11	48
016061031	F -29	14	048090342	T -3	38		D -16	10	108549001	F -23	14
	G -13	16	060300606	H -8	16		D -25	10	108801001	P -59	28
017500812	S -44	36	060350616	C -27	6		E -2	12	108802001	J -5	18
017762013	Z1 -40	48		C -30	6		F -44	14		P -58	28
018062032	C -50	8	060400516	T -13	38		N -3	26	109714000	Z1 -34	48
	C -60	8	061350616	Q -19	32		P -8	28	110087001	W -17	46
	F -15	14		Q -37	32		Q -40	32		Z1 -44	48
	G -17	16	062020806	U1 -4	40		S -53	36	110161004	N -1	26
018062532	C -57	8	062060812	U1 -15	40		T -23	38	112609001	C -14	6
018401036	C -4	6	062060816	F -7	14		U1 -18	40	112728001	C -33	6
018501632	U1 -20	40		F -50	14		U1 -43	40	112753001	P -67	30
021060306	E -18	12		N -5	26		U1 -45	40	113014000	B -7	4
	E -35	12		P -49	28	062501006	Z2 -38	50	113050001	L -10	24
	S -39	36		S -12	36	062501016	A -10	2	114483002	Z1 -36	48
	Z1 -24	48	062061012	S -10	36		D -4	10	114486002	Z1 -35	48
021300106	Q -11	32	062061016	G -7	16		F -3	14	114967001	W -16	46
021350106	J -15	18		K1 -60	22		P -17	28		Z1 -43	48
	S -22	36		P -68	30		S -8	36	115947001	K1 -54	22
021400106	U1 -10	40	062061616	C -48	8		S -18	36	116010001	A -21	2
021400164	W -22	46		S -30	36		T -14	38	117006001	B -6	4
021500106	E -28	12	062260316	C -16	6		T -28	38	118735002	C -51	8
	F -52	14	062260516	C -20	6	062501212	K1 -42	20	118837001	Z1 -3	48
	Z2 -20	50	062300416	J -23	18		K1 -42	22	118954000	F -10	14
	Z2 -29	50	062300612	K1 -19	20	062501216	A -7	2	122991001	Z1 -1	48
	Z2 -34	50		K1 -19	22		F -41	14	129458102	F -22	14
	Z2 -36	50	062300616	Q -39	32		F -46	14	138843001	Z2 -28	50
021500316	K1 -12	20		T -8	38		F -51	14	140063001	A -1	2
025030132	J -22	18		U1 -13	40	062501406	Z2 -32	50	140647101	T -9	38
025040173	U2 -7	42	062350512	Q -22	32	062501416	A -5	2		U1 -5	40
025040232	B -23	4	062350516	C -37	6		A -9	2	140890009	P -66	30
025040233	W -20	46		C -42	8		D -21	10	141208001	E -5	12
025050236	F -47	14		D -8	10		E -27	12	141331002	S -35	36
	S -45	36	062350816	C -32	6	062661212	T -26	38		S -37	36
	T -24	38	062351216	S -21	36	071063550	D -19	10	141544001	K1 -37	20
025050336	F -42	14	062400616	J -18	18	072600480	M -9	26		K1 -37	22
025060132	J -13	18		J -33	18	081004070	P -27	28	142002001	Z1 -6	48
025060136	K1 -61	22		K1 -27	20		P -31	28	142026003	W -13	46
	R -6	34		K1 -29	20	081009070	R -5	34	142027001	W -14	46
	R -15	34		K1 -32	20	081038070	P -20	28	142274101	P -36	28

from the library of Diamond Needle Corp

CODE	REF.NO	Page	CODE	REF.NO	Page	CODE	REF.NO	Page	CODE	REF.NO	Page
142443001	Z1 -2	48	149863001	D -28	10	J01411001	U2 -11	42	S01641101	Ga	53
142721001	Z1 -8	48	149938001	Ga	53	J02725001	U2 -17	42	S01644001	Ga	53
142746002	F -21	14	149939001	Ga	53	J03733001	U2 -4	42	S01646001	Ga	53
142990001	Z2 -26	50	149940001	Ga	53	J03739001	U2 -13	42	S01928151	K1 -62	22
142997001	Z2 -6	50	149942001	Ga	53	J03939001	U2 -9	42		Z1 -12	48
143548000	W -26	46	149948001	Ga	53	J03955001	U1 -22	40	S02664001	T -5	38
143549000	W -25	46	149949001	Ga	53	J03956001	U1 -24	40	S02665000	T -6	38
143611201	F -8	14	149950101	Ga	53	J03957001	U1 -25	40	S02747101	Z2 -12	50
143612100	F -9	14	149952101	Ga	53	J03958001	U1 -27	40	S02779009	Z2 -22	50
143613051	F -16	14	149954001	Ga	53	J03964001	U1 -38	40	S02788009	Z2 -23	50
143616001	F -17	14	150173003	Z2 -16	50	J03975001	U1 -51	40	S02789009	Z2 -24	50
143882001	Z1 -30	48	150174000	Z2 -10	50	J03976001	U1 -52	40	S04109001	Z2 -5	50
143910009	Z1 -31	48		Z2 -14	50	J03983001	U1 -55	40	S05246000	P -35	28
144226001	Z1 -15	48	150179002	Z2 -18	50	J03984001	U1 -56	40	S07027001	W -18	46
144504001	Q -27	32	150182000	Z2 -3	50	J04086001	V -1	44	S07030009	W -23	46
145446001	Q -23	32	150183000	Z2 -25	50		Sp1	44	S07031009	W -24	46
	R -29	34	150185009	Z2 -27	50	J04093001	V -5	44	S07045009	W -12	46
145573000	Z1 -16	48	150188009	Z2 -21	50		Sp1	44	S07346101	E -6	12
146039001	Z1 -38	48	150206002	Z2 -8	50	J04096001	V -7	44	S07349001	E -23	12
146046000	W -27	46	150820001	D -18	10		Sp1	44	S07350001	E -36	12
146194000	W -28	46	151025001	K2 -2	24	J04097001	U2 -8	42	S07351001	E -13	12
146293001	Z1 -26	48	151027001	K2 -7	24	J04098001	U2 -8	42	S07355051	E -26	12
146367001	W -10	46	151034001	K2 -6	24	J04099001	U2 -14	42	S07374109	F -38	14
148511001	T -2	38	151035001	K2 -5	24	J04100001	U2 -15	42	S07376001	F -48	14
148536001	S -48	36	151043001	Sp	52	J04115001	Wa	51	S07401001	Ga	56
148539101	S -50	36	153132000	G -19	16	J04134001	V -6	44	S07403001	Ga	56
148546001	S -14	36	153138001	G -10	16		Sp1	44	S07405101	Ga	56
	T -15	38	153230101	Z1 -27	48	J04149001	V -8	44	S07409001	Ga	56
148559100	S -27	36	154125001	Z1 -7	48		Sp1	44	S07410001	Ga	56
148602001	K1 -63	22	154514001	U1 -9	40	J04167001	U2 -10	42	S07411001	Ga	56
148679001	Ga	53	154560001	Q -28	32	J04168001	U2 -23	42	S07419001	K1 -6	20
148683001	Ga	53	154567000	C -44	8	J04169001	U2 -22	42	S07420000	K1 -5	20
148689001	Ga	53	154729001	G -2	16	J04195001	U1 -53	40	S07424001	T -30	38
148697001	Ga	53	154730001	G -3	16	J04210001	U2 -24	42	S07494001	L -12	24
148698001	Ga	53	154731000	G -4	16	J04230001	U1 -34	40	S07509001	S -28	36
148699001	Ga	53	154965001	K1 -17	20	J04243001	U2 -25	42	S07525000	K1 -36	20
148700001	Ga	53		K1 -17	22	J04251001	V -11	44		K1 -36	22
148701001	Ga	53	155510001	Q -29	32		Sp1	44	S07526201	S -47	36
148702001	Ga	53	155722001	Ga	53	J04255001	V -12	44	S07527001	S -49	36
148703001	Ga	53	155724001	Ga	53		Sp1	44	S07529001	E -14	12
148704001	Ga	53	155851001	Ga	53	J04273001	U1 -54	40		E -38	12
148705001	Ga	53	155853001	Ga	53	J04296001	U1 -36	40	S07549101	T -18	38
149095001	G -18	16	155855001	Ga	53	J04393001	U2 -1	42	S07550001	T -19	38
149570001	Z1 -9	48	155857001	Ga	53	J04438001	U2 -2	42	S07552001	T -25	38
149578000	Z1 -19	48	156112003	Z2 -15	50	J04440001	U2 -3	42	S07553001	T -29	38
149604001	C -8	6	156816001	Ga	53	J04468001	U2 -16	42	S07558309	Z2 -1	50
149605001	C -9	6	156818001	Ga	53	J04469001	V -3	44	S07575000	C -23	6
149608001	C -13	6	156819001	Ga	53		Sp1	44	S07575001	C -23	6
149610001	C -17	6	158115001	M -13	26	J04470001	V -10	44	S07575002	C -23	6
149611101	C -18	6	158756001	Ga	55		Sp1	44	S07575003	C -23	6
149622001	C -25	6	159398001	Ga	53	J80964201	U2 -20	42	S07575004	C -23	6
149671101	Ga	53	159801001	K2 -8	24	J80965001	U2 -21	42	S07575005	C -23	6
149673101	Ga	53	159802001	K2 -9	24	J80966101	U2 -21	42	S07575006	C -23	6
149675001	Ga	53	159805001	Q -24	32	J80967001	U2 -18	42	S07575007	C -23	6
149676001	Ga	53	228475000	P -13	28	J80968001	U2 -18	42	S07575008	C -23	6
149677001	Ga	53	340400001	S -54	36	J80970001	U2 -19	42	S07575009	C -23	6
149687001	Ga	53	BMP2060-0000000-0G40			J80971001	U1 -30	40	S07575010	C -23	6
149689001	Ga	53		U1 -48	40	J80973001	U1 -49	40	S07575011	C -23	6
149691001	Ga	53	BMP2060-0000000-CG40			J80974001	U1 -50	40	S07588101	D -26	10
149692001	Ga	53		U1 -48	40	J80990001	U1 -19	40	S07676001	Ga	56
149799000	W -29	46	BMP2060-0000000-EG40			S01005000	Z2 -11	50	S07678001	Ga	56
149827001	C -10	6		U1 -48	40	S01567001	K2 -3	24	S07680001	Ga	56
149831101	L -5	24	J00494001	U2 -12	42	S01568001	K2 -4	24	S07681001	Ga	56

索引 / INDEX

CODE	REF.NO	Page	CODE	REF.NO	Page	CODE	REF.NO	Page	CODE	REF.NO	Page
S07684101	Ga	56	S15744001	Ga	53	S31032001	R -31	34	SA1360001	R -26	34
S07729001	W -11	46	S15747001	Ga	53	S31885001	Z1 -45	48	SA1385001	U1 -1	40
S07748001	Sp	52		Ga	56	S32904000	H -4	16	SA1388001	H -12	16
S07876101	P -43	28	S15748001	Ga	53	S32905000	H -5	16	SA1390001	H -6	16
S07905001	Ga	55		Ga	56	S32907000	H -7	16	SA1683111	Sp	52
S09260001	K1 -4	20	S15749001	Ga	53	S34281000	H -3	16	SA1752014	Z1 -10	48
S09261001	K1 -4	20		Ga	56	S34438051	A -20	2	SA1752022	Z1 -10	48
S10507001	Ga	53	S15750001	Ga	53	S34561001	C -11	6	SA1962001	Z1 -32	48
S10509101	Ga	53		Ga	56	S34562001	C -12	6	SA1963001	Z1 -33	48
S10510001	Ga	53	S15753001	Ga	53	S34756001	Z1 -42	48	SA1969001	Z1 -29	48
S10550001	W -9	46		Ga	56	S36522001	Ga	53	SA1971101	R -1	34
S10780001	E -37	12	S15754001	Ga	53	S36550001	Ga	53	SA1975001	R -3	34
S11244001	L -7	24		Ga	56	S36554001	Ga	53	SA1978001	R -4	34
S12441001	R -32	34	S15755001	Ga	53	S36556001	Ga	53	SA1980001	R -7	34
S13085001	L -4	24		Ga	56	S36663051	A -19	2	SA1981101	R -10	34
S13160001	B -15	4	S15756001	Ga	53	S37037001	Z2 -31	50	SA1982101	R -11	34
S13621001	Ga	56		Ga	56		Z2 -35	50	SA1983001	R -12	34
S13623101	Ga	56	S15759001	Ga	53	S37038001	Z2 -30	50	SA1984001	R -16	34
S13624001	Ga	56	S15760001	Ga	53	S37060001	A -23	2	SA1985001	R -18	34
S14530001	Ga	53	S15761001	Ga	53		Wa	51	SA1988001	R -20	34
S14532001	Ga	53	S15762001	Ga	53	S37682001	Ga	56	SA1989001	R -21	34
S14533001	Ga	53	S15765001	Ga	53	S38212001	K1 -16	20	SA1990101	R -22	34
S14534001	Ga	53		Ga	56		K1 -16	22	SA1991001	R -23	34
S14536001	Ga	53	S15766001	Ga	53	S38266000	P -10	28	SA1992101	R -25	34
S15705001	Ga	53		Ga	56	S38274001	Q -32	32	SA1994001	R -28	34
S15706001	Ga	53	S15767001	Ga	53	S38278001	Z1 -41	48	SA1998001	S -52	36
S15707001	Ga	53		Ga	56	S38300001	Z1 -37	48	SA2040001	A -24	2
S15708001	Ga	53	S15768001	Ga	53	S38351001	W -8	46		Wa	51
S15711001	Ga	53		Ga	56		Wa	51	SA2041001	A -24	2
	Ga	56	S15771001	Ga	53	S38421001	T -22	38		Wa	51
S15712001	Ga	53	S15772001	Ga	53	S38426000	T -4	38	SA2165001	E -32	12
	Ga	56	S15773001	Ga	53	S38427001	F -19	14	SA2190001	R -24	34
S15713001	Ga	53	S15774001	Ga	53	S38542001	Ga	56	SA2270001	H -2	16
	Ga	56	S15889001	Z1 -25	48	S38543001	Ga	56	SA2354001	U1 -40	40
S15714001	Ga	53	S17774001	Z1 -4	48	S38544001	Ga	56	SA2378001	S -32	36
	Ga	56	S18964001	D -15	10	S38648001	Z2 -9	50	SA2441001	A -6	2
S15717001	Ga	53	S20681000	Q -25	32	S38687000	S -51	36	SA2442101	A -8	2
S15718001	Ga	53	S20682105	Q -26	32	S38707001	B -4	4	SA2444101	A -13	2
S15719001	Ga	53	S20901001	Ga	53	S38710001	B -17	4	SA2445101	A -14	2
S15720001	Ga	53	S20903001	Ga	53	S38713100	B -20	4	SA2447001	A -15	2
S15723001	Ga	53	S20905001	Ga	53	S38744101	U1 -2	40	SA2449001	A -17	2
	Ga	56	S21798001	Z2 -17	50	S39048001	T -7	38	SA2460001	B -16	4
S15724001	Ga	53	S23418002	R -19	34	S39051001	E -12	12	SA2461001	B -19	4
	Ga	56		Z1 -28	48	S39830101	F -27	14	SA2462001	B -33	4
S15725001	Ga	53	S23460001	C -53	8	S40639001	Z2 -13	50	SA2463001	B -24	4
	Ga	56	S23651001	B -10	4	S41955051	W -6	46	SA2469001	B -26	4
S15726001	Ga	53		B -18	4	S42198051	W -4	46	SA2474201	C -3	6
	Ga	56		J -9	18	S42199051	W -5	46	SA2479001	A -16	2
S15729001	Ga	53		K1 -40	20	S42200051	W -7	46		A -18	2
S15730001	Ga	53		K1 -40	22	S48204000	C -62	8	SA2485001	C -45	8
S15731001	Ga	53	S25234001	B -3	4	S49623000	P -14	28	SA2486101	C -47	8
S15732001	Ga	53	S25235001	B -11	4	S50098101	F -24	14	SA2489001	C -49	8
S15735001	Ga	53	S25236001	B -12	4	S51282101	Z2 -4	50	SA2490101	C -52	8
	Ga	56		F -13	14	S51283001	Z2 -2	50	SA2493001	C -58	8
S15736001	Ga	53		M -11	26	S54024001	W -3	46	SA2494001	C -59	8
	Ga	56		S -33	36	S54025001	W -2	46	SA2495001	E -1	12
S15737001	Ga	53	S25260001	B -8	4	S55663001	Z1 -14	48	SA2496001	E -7	12
	Ga	56		C -46	8	SA1120001	B -9	4	SA2498001	E -8	12
S15738001	Ga	53	S25289001	E -9	12	SA1174001	E -3	12	SA2499001	E -10	12
	Ga	56	S25344001	Z1 -22	48	SA1175001	E -4	12	SA2500001	E -19	12
S15741001	Ga	53	S25475001	Z1 -23	48	SA1179001	E -22	12	SA2501001	E -20	12
S15742001	Ga	53	S25789000	R -9	34		E -31	12	SA2502001	E -21	12
S15743001	Ga	53	S31006001	E -11	12		E -33	12	SA2504001	E -24	12

from the library of Diamond Needle Corp

CODE	REF.NO	Page	CODE	REF.NO	Page	CODE	REF.NO	Page	CODE	REF.NO	Page
SA2504001	T -20	38	SA2598101	P -44	28	SA2680001	T -1	38	SA3147001	P -28	28
SA2506001	E -29	12	SA2599001	P -26	28	SA2682001	T -16	38		P -32	28
SA2507001	E -30	12		P -30	28	SA2683001	T -17	38		P -40	28
SA2509001	F -1	14	SA2604001	P -55	28	SA2684001	T -27	38	SA3175001	U1 -12	40
SA2511001	F -2	14	SA2605001	P -56	28	SA2686001	U1 -3	40	SA3415001	Q -2	32
SA2512001	F -4	14	SA2606101	P -60	28	SA2687001	U1 -42	40	SA3416001	Q -2	32
SA2515001	F -5	14	SA2607001	Q -1	32	SA2688001	H -1	16	SA3417001	Q -1	32
SA2516001	F -6	14	SA2613001	Q -4	32	SA2689001	H -10	16	SA3840001	J -10	18
SA2518001	F -11	14	SA2614001	Q -5	32	SA2691101	Z1 -17	48	SA3855001	J -1	18
SA2521001	F -14	14	SA2615001	Q -6	32	SA2692101	Z1 -18	48	SA3856001	K1 -8	20
SA2523001	F -26	14	SA2619001	Q -7	32	SA2696001	T -12	38	SA3859001	K1 -9	20
SA2525001	F -28	14	SA2620001	Q -9	32	SA2707001	W -1	46	SA3887001	J -20	18
SA2526001	F -30	14	SA2621001	Q -10	32	SA2712001	U1 -17	40	SA3888001	J -21	18
SA2527001	F -31	14	SA2623001	Q -8	32	SA2717001	K1 -33	20	SA3889101	K1 -13	20
SA2528101	F -33	14	SA2624001	Q -13	32		K1 -33	22		K1 -13	22
SA2529101	F -34	14	SA2625001	Q -14	32	SA2722001	K1 -55	22	SA3890001	M -1	26
SA2530001	F -37	14	SA2626001	Q -12	32	SA2723001	P -21	28	SA3891001	M -3	26
SA2531001	F -39	14		Q -15	32	SA2724001	J -34	18	SA3894001	K1 -31	20
SA2532001	F -45	14	SA2627001	Q -16	32		P -22	28		K1 -31	22
SA2533001	F -49	14	SA2628001	Q -17	32	SA2727101	P -34	28	SA3896001	P -25	28
SA2535101	G -5	16	SA2629001	Q -18	32	SA2728001	S -7	36	SA3898001	P -29	28
SA2536001	G -11	16	SA2630001	Q -21	32	SA2732001	T -11	38	SA3912001	K1 -38	20
SA2539001	G -16	16	SA2632001	Q -30	32	SA2806001	J -30	18		K1 -38	22
SA2540001	G -12	16	SA2633001	Q -33	32	SA2814201	P -1	28	SA3916001	K1 -51	22
SA2541001	F -40	14	SA2634001	Q -36	32	SA2824001	Q -20	32	SA3923001	P -53	28
SA2543001	J -4	18	SA2635001	Q -38	32	SA2825001	K1 -52	22	SA3924001	A -2	2
SA2544001	J -6	18	SA2636001	Q -41	32	SA2826001	K1 -43	22	SA3946001	P -3	28
SA2546001	J -8	18	SA2637001	Q -43	32	SA2859000	S -17	36	SA3961001	K1 -2	20
SA2550001	J -24	18	SA2638001	Q -44	32	SA2860001	S -16	36	SA3965001	J -2	18
SA2551001	J -25	18	SA2640001	Q -45	32	SA2861101	B -13	4	SA3988001	K1 -50	22
SA2553001	J -16	18	SA2642001	S -1	36	SA2867001	Z2 -7	50	SA3990001	J -19	18
SA2554001	J -17	18	SA2643001	S -2	36	SA2927001	J -12	18	SA4009001	J -32	18
SA2555001	J -27	18	SA2644001	S -3	36	SA2928001	J -28	18	SA4011001	J -35	18
SA2556001	K1 -53	22	SA2645001	S -4	36	SA2929001	A -22	2	SA4012001	K1 -30	20
	K1 -57	22		S -46	36		P -9	28		K1 -30	22
SA2557001	K1 -7	20	SA2646001	S -6	36		P -18	28	SA4014001	P -65	30
SA2560001	K1 -10	20	SA2647001	S -9	36	SA2935101	B -14	4	SA4026001	K1 -14	20
SA2562101	K1 -18	20	SA2648001	S -11	36	SA2956001	P -4	28		K1 -14	22
SA2563101	K1 -45	22	SA2651001	S -13	36	SA2957001	P -5	28	SA4028001	J -3	18
SA2565001	K1 -56	22	SA2652101	S -15	36	SA2992001	G -8	16	SA4029001	K1 -3	20
SA2566001	J -14	18	SA2653001	S -19	36		G -14	16	SA4033101	P -12	28
SA2567001	K1 -58	22	SA2655001	S -20	36	SA3025001	U1 -41	40	SA4038001	K1 -4	20
SA2568001	K1 -59	22	SA2657001	S -23	36	SA3037001	P -37	28	SA4040001	U1 -11	40
SA2571001	M -5	26	SA2658001	S -24	36	SA3040001	P -2	28	SA4042001	K1 -26	20
SA2572001	K1 -20	20	SA2659001	S -26	36		P -38	28	SA4043001	K1 -47	22
SA2574001	K1 -21	20	SA2661001	S -31	36	SA3044001	P -50	28	SA4044001	K1 -28	20
	K1 -24	20	SA2663001	S -34	36	SA3045201	P -47	28	SA4045001	K1 -48	22
	K1 -21	22	SA2665001	S -36	36	SA3046001	P -48	28	SA4050001	Ga	53
	K1 -24	22	SA2667001	S -38	36	SA3047001	P -52	28	SA4051001	Ga	53
SA2575001	K1 -22	20	SA2668001	S -40	36	SA3048101	P -62	28	SA4117001	C -54	8
	K1 -22	22	SA2669001	S -41	36	SA3049001	P -63	28	SA4118001	C -56	8
SA2578001	E -41	12	SA2670001	K1 -49	22	SA3054001	K1 -25	20	SA4149101	E -34	12
SA2579001	K1 -46	22	SA2671001	K1 -41	20	SA3055101	P -6	28	SA4212001	Q -3	32
SA2580101	M -6	26	SA2672001	S -42	36		P -7	28	SA4213001	M -15	26
SA2582001	Z1 -20	48	SA2673001	S -43	36		P -23	28	SA4364001	A -3	2
SA2584001	M -8	26	SA2675001	K1 -39	20		P -51	28	SA4370101	A -11	2
SA2585001	F -12	14		K1 -39	22	SA3056001	F -20	14	SA4373001	B -2	4
	M -10	26	SA2676001	K1 -34	20	SA3057001	B -28	4	SA4376101	B -29	4
	M -14	26		K1 -34	22	SA3059001	B -31	4	SA4377001	C -1	6
SA2587101	M -12	26	SA2677001	E -16	12	SA3060001	P -39	28	SA4378001	C -2	6
SA2590001	Z1 -21	48		E -40	12	SA3061001	P -33	28	SA4382001	C -5	6
SA2596001	P -41	28	SA2678001	N -2	26	SA3065001	B -30	4	SA4385001	C -6	6
SA2597001	P -42	28	SA2679001	N -4	26	SA3072001	G -1	16	SA4387001	C -7	6

索引 / INDEX

CODE	REF.NO	Page	CODE	REF.NO	Page	CODE	REF.NO	Page	CODE	REF.NO	Page
SA4387002	C -7	6									
SA4387003	C -7	6									
SA4389001	C -21	6									
SA4391001	C -15	6									
SA4392001	C -19	6									
SA4393001	C -34	6									
SA4394001	C -35	6									
SA4395001	C -22	6									
SA4396001	C -26	6									
SA4397001	C -28	6									
SA4398001	C -29	6									
SA4399001	C -31	6									
SA4400001	C -38	6									
SA4401001	C -36	6									
SA4402001	D -1	10									
SA4404001	D -5	10									
SA4405001	D -7	10									
SA4406001	D -10	10									
SA4408001	D -12	10									
SA4409001	D -13	10									
SA4411101	D -14	10									
SA4412001	D -17	10									
SA4413001	D -20	10									
SA4414001	D -23	10									
SA4415001	D -24	10									
SA4416001	D -27	10									
SA4417001	D -29	10									
SA4418001	D -31	10									
SA4419001	D -15	10									
SA4435101	K1 -1	20									
SA4436101	K1 -44	20									
SA4441001	D -6	10									
SA4444001	K1 -4	20									
SA4458001	K1 -43	22									
SA4506001	Q -34	32									
SA4507001	Q -35	32									
SA4509001	M -7	26									
SA4538001	J -29	18									
SA4549001	K1 -20	22									
SA4551001	B -1	4									
SA4583001	C -24	6									
SA4585001	M -2	26									
	M -4	26									
SA5154201	P -16	28									
SA5155001	C -40	6									
SA5200001	U1 -44	40									
SA5224001	P -11	28									
SA5237101	C -41	8									
SA5293001	P -15	28									
SA5332001	C -61	8									
SA5333001	D -9	10									
SA5336001	D -3	10									
SA5588001	D -22	10									
SA6150001	J -11	18									
SA6166001	B -5	4									
SA6294001	K1 -64	20									
	K1 -64	22									
SA6301001	K1 -23	20									
	K1 -23	22									
SA6307001	K1 -65	20									
	K1 -65	22									
W01519001	J -31	18									

from the library of Diamond Needle Corp

brother®

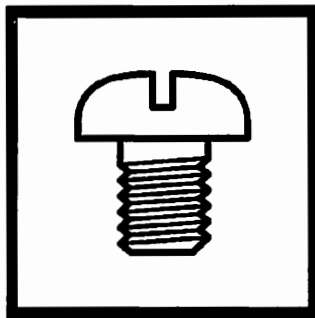

パーツブック
PARTS BOOK

ブラザー工業株式会社 <http://www.brother.co.jp/>

〒467-8561 名古屋市瑞穂区苗代町 15 番 1 号 TEL (052) 824-2392

BROTHER INDUSTRIES, LTD. <http://www.brother.com/>

15-1, Naeshiro-cho, Mizuho-ku, Nagoya 467-8561, Japan. Phone : 81-52-824-2177

Printed in Japan

T-8452A
SA4425-001
2005.02.B (1)

from the library of Diamond Needle Corp